

# Orange Bytes

Award-Winning Newsletter of the North Orange County Computer Club\*

Vol 38 • No 10

October 2013, \$1.50

## Main Meeting October 6

Larry Klees will speak about ways that digital imaging is changing our lives, part 3. (See page 3)

Big prizes for our October raffles (such as a PNY Geforce GT 610 Video card) (See page 4)

September raffle winners' pix (See page 16)

The Consignment Table and E-Waste Collection WILL be held at the October 2013 meeting

## Special Interest Group (SIG) & Main Meeting

### 9:00 a.m.

**Linux for Desktop Users**..... Science 131

Virtualization under Linux, Beginner's Qs

**Visual Programming** ..... Science 111

Visual Basic, Visual Basic Script, Visual C++ and Visual J++

**Exploring New Technology**..... Science 109

Possibly BYO PC

**Beginners Digital Photography** ..... Science 131A

An Asus tablet and a new device called Chromecast.

**Microsoft Word, Excel, and Outlook** ..... Science 306

Three parts of the Microsoft Office Suite plus Open Office

*Books for Review & Coffee & Donuts: Irvine Hall Lobby*

### 10:30 a.m.

**Beginners PC Q & A**..... Irvine Hall

For newbies who need help with their hardware, etc.

**Linux Administration** ..... Science 131

More topics about the Linux operating system.

**Apple Products**..... Science 127

Apple products, projects & problems.

**STEM (Science, Technology, Engineering and Math)**

If you are interested, See page 23.

### 10:30 a.m.

**Advanced Digital Photography**..... Science 131A

Panoramic Photographs and the methods for making them.

**Understanding Operating Systems**..... Science 111

Help with Microsoft Windows operating systems

**Mobile Computing**..... Science 109

SIM card used in Greece

**Microsoft Access** ..... Science 306

Database applications and more

### 12:00 Noon

**PIG SIG**..... Hashinger Courtyard

Brown bag lunch outside Irvine Hall

**Visual Basic for Applications (VBA)** ..... Science 306

Access & Excel VBA code

### 12:30 p.m.

**Advanced PC Q & A**..... Irvine Hall

PC hardware & software topics and the Internet

**2:00 p.m. Main Meeting** ..... Irvine Hall

**NOCCC website:**

<http://www.noccc.org>

**Future Meeting Dates in 2013:**

**November 3, December 8\***

(\* = Second Sunday)



\*SWUG 1st Prize in 2004, 2005, 2006 APCUG 2nd Prize in 2003, 2004, 2005

Founded April 1976

## Table of Contents

SIGs Schedule for October .....	1
Future 2013 Meeting Dates .....	1
Orange Bytes Staff .....	2
October 2013 Main Meeting.....	3
President’s Message .....	3
NOCCC Website Information .....	3
October 2013 Club Raffle Prizes.....	4
Save Your Parking Permits .....	4
Membership Benefits.....	4
Consignment Table & E-Waste .....	5
NOCCC Officers .....	5
NOCCC Help Volunteers .....	6
NOCCC SIG Leaders .....	6
Trouble Shooting Your PC .....	7
Installing a WD TV Live Hub .....	7
Create a Sys. Repair Disk for Win 7 .....	7
Got Windows 8? Then Get Start8.....	8
Internet Alerts Can Keep You Informed .....	8
Changing Gridline Color .....	9
Applying Bullets from the Keyboard .....	10
Products Available for Review.....	11
USB3 Front Bay Interface Review .....	12
Windows 7 for Dummies, Pocket Edition ....	13
Orange Bytes in Color .....	13
September 2013 Main Meeting Report.....	14
September 2013 Raffle Winners.....	16
Apple Products SIG .....	17
Microsoft Office SIG.....	17
Visual Programming SIG .....	17
Understanding Operating Systems SIG .....	17
Pig SIG .....	17
Beginner’s Digital Photography SIG.....	18
Advanced Digital Photography SIG .....	18
Linux Desktop & Administrator SIGs.....	19
Link to NOCCC Bylaws.....	19
PC Q&A SIG.....	20
Microsoft Access SIG.....	21
Visual Basic for Apps SIG .....	21
Exploring New Technology SIG .....	22
Mobile Computing SIG .....	22
Proposed New STEM SIG.....	23
September 2013 Board Meeting Minutes .....	23
Membership Chairman’s Column .....	24
NOCCC Fee Schedule .....	25
Renewed Members .....	25
Transportation Information .....	25
Ad Space & Members’ Ads.....	26
Commercial Display Ads .....	26
Publication Information.....	27
Membership Application .....	27
Are You a NOCCC Member? .....	28

## Orange Bytes Staff

**Editor** - *Makes final selections of articles and lays out the newsletter. Converts the newsletter to PDF format and sends it to the printer*  
 Steven Breitbart ..... editor@noccc.org

**Associate Editors** – *Write articles for the newsletter.*  
 Open

**Proofreaders** - *Proofread the newsletter in final draft form. Make necessary changes and corrections.*  
 Larry Klees ..... (714) 394-1870.....larryklees@yahoo.com

**Circulation** - *Oversees mailing and distribution of the newsletter.*  
 Richard Miller..... (714) 309-1504.....reviews@noccc.org

**Reviews Editor** - *Communicates with the vendors and members who evaluate products and write reviews. Makes sure members meet deadlines. Sends a copy of the newsletter to vendors of products we review.*  
 Richard Miller..... (714) 309-1504.....reviews@noccc.org

### VOLUNTEERS NEEDED

The following positions are available. If you are interested, **contact the editor at editor@noccc.org.**

**Social Media Contacts** – *Maintain connections with social media on behalf of the club and write articles for the newsletter about them.*

**Associate Editors** - *Write articles for the newsletter.*

**Proofreaders** - *Proofread the newsletter in final draft form.*

**Commercial Advertising** - *Obtain ads from vendors for the newsletter. See page 26.*

**Classified Advertising** - *Obtain free, computer-related, non-commercial ads for the newsletter for NOCCC members. See page 26.*

**APCUG Representative** – *Represent the NOCCC at APCUG*

***Celebrating 36 years of  
 “Friends Helping  
 Friends”***



## October 6 Main Meeting

2 p.m. Irvine Hall

Our October 6 speaker is Larry Klees, Advanced Digital Photography SIG Leader. He will be speaking about Ways that Digital Imaging is Changing Our Lives, part three. Larry spoke about this in May and June 2013. So, if you want to read all about it, check the June and July 2013 Orange Bytes issues, Main Meeting Report. Larry said that the last meetings were too short to cover this topic; this time we will touch on CT, PET and MRI scans plus more types of 3D printing and Bézier curves.

Larry has been involved with computers, photography and printing for many years. He has been leading the Advanced Digital Photography SIG for several years and has introduced attendees to all sorts of unusual and innovative techniques for taking photographs.

**On November 3**, our planned speaker is Hunter Routhroff who will speak about 3-D printing. He works as a structural engineer and uses the 3-D printer mainly for making jewelry, which he and his wife sell. He went to Cal Poly Pomona and the University of Washington.

## President's Message

By Dr. Don Armstrong, NOCCC

The September main meeting was a great step forward in our understanding of the NOCCC website. Thanks to our able webmaster, **Rudy Lauterbach**, we should all have much better awareness of how to use and benefit from the electronic avenues for club information and action.



Before I forget, members who attend the October main meeting will receive one of the new triple benefit NOCCC pens. Not only is it an excellent ball point pen with our name on it, but it also has a bright LED light on one end and the other end has a soft stylus for use on touch screens like on your smart phones, tablets, etc. We will present a pen to the guest presenters and certain members of the Chapman University community. We will include a pen in each raffle. And, if we have any left, members may trade a \$5.00 donation to the club for an extra or a gift pen. Non-members will have to donate \$10.00 for the pen.

Good public relations are important for any organization. All members should be continually in the process of contacting others in our sphere of interest and telling them about NOCCC. In addition to the members' efforts, we intend to use snail-mail to reach all the companies and shops in a one or two mile radius from Chapman. The goals will be to introduce our club, direct them to our website and invite them our SIGs and main meetings. **Tia Williams** will be drafting the cover letter, preparing an informative flyer, and accumulating the addresses in an *Excel*

spreadsheet. Then she will use the mail-merge capability of *Word* to address the correspondence to the individual businesses.

It is being discussed that having a meeting on a holiday weekend is not a good idea. The current opinion is that in the future, on Labor Day or Monday major holiday weekends, we will try to defer the meeting to another Sunday or in the worst case, cancel it.

Although at first this may be difficult to accept, a basic concept for all of us to keep in mind when upset by a situation is that personal peace depends on recognizing that you're not upset because of *the situation*, you are upset because of how you *perceive* the situation. Perceptions are complex brain products that depend on many things including information, education and experiences all the way from childhood.

Why do I mention this? Because I would like to see members develop the perception of how important individual time contribution is to the operation of this club. Major keys to productivity and personal satisfaction are first, recognizing how much your ideas and activities would be appreciated and second, that you are not designed to be perfect in everything you do.

The next question may be "But what can I do?" Briefly, we need folks to help with the newsletter. We need members to assist with setting up meetings on those special Sundays. We would like to have the committees filled. We need a hearty soul to be the Vice President.

We shall revisit the details with volunteers and in future messages here.

**Have You Checked Out the NOCCC Website Lately?**

>> [www.noccc.org](http://www.noccc.org) <<

**Great looking, Easy to navigate, Orange Bytes Archive from 2002 to date, and New Features are added all the time!**

Rudy has developed a members-only page. As of Feb. 4, 2013, we have a working login capability using a member's badge number and email address from the club's database.

You can assist by trying all of the buttons and text fields on the "log-in" page. Give it a stress test. Try a "bad" login. Try different browsers. Try to hack your way in. Then send an email to webmaster Rudy ([rblauter@cs.com](mailto:rblauter@cs.com)) stating what browser you used, what worked and what didn't work.

In the meantime, Rudy will be working on appropriate material for the members-only page. Suggestions are welcome.

## THE OCTOBER 2013 CLUB RAFFLES PRIZES



### GENERAL DRAWING PRIZES\*:

- ❖ PNY Geforce GT 610 Video card VGA/DVI/HDMI
- ❖ Pocket Power 5A/h Battery, Solar/USB charger for cell phones & USB devices
- ❖ Gear Head Wireless Optical mouse
- ❖ USB powered Magnet base personal fan

*\* Parking stubs are good for two raffle tickets each!  
See the article immediately below this list!*

### MEMBERS-ONLY DRAWING PRIZES:

**Wear your NOCCC Badge and get a free ticket! Wear your NOCCC shirt too & get a second free ticket!**

- ❖ On Networks 802.11n WiFi Router
- ❖ Pocket Power 5A/h Battery, Solar/USB charger for cell phones & USB devices
- ❖ Gear Head Wireless Optical mouse
- ❖ USB powered Magnet base personal fan

## Save Your Parking Permits!

To offset the cost of parking in the **Lastinger Underground Parking Structure**, the NOCCC Board approved a motion to give each member two NOCCC General Drawing raffle tickets in exchange for the Lastinger-parking permit. Turn in the bottom-half “receipt” part of your permit to Gerry Resch, the Raffle Leader, and he will exchange it for two raffle tickets.

Chapman University has allowed us to park in the Lastinger Parking Structure under Wilson Field for only \$2 for the whole day of our meeting; normally \$2 is good for only two hours. The advantages of parking there are clear; you don’t have to drive around looking for a legal spot (remember, don’t park on the private home side of the street), the car doesn’t get hot and you don’t have to parallel park. There is even an elevator available to get down to the parking area.

## Membership Benefits

As a valued member, we bring you a section of discounts and offers as part of the entire “Benefit of Belonging.” (Caveat: we are unable to endorse these companies, but make these offers available as a service to our members.)

### User Group Offers - Software and Hardware

**User Group Relations** – You can now order the latest release of **Acronis True Image 2013** from **Gene Barlow** for only \$25 (download) or \$25 plus S&H (on a CD). This top-rated backup utility has many new features and will work with Windows 8. Use the following link for special pricing for user group members: [www.ugr.com/TrueImage.html](http://www.ugr.com/TrueImage.html).

**Techsmith** - You can get **SnagIt 11**, an outstanding screen capture program, and **Camtasia Studio 8**, to quickly record, edit and publish multimedia demos and presentations, bundle for \$269, an \$81 savings. Go to <https://store.techsmith.com/government.asp>. You can download SnagIt 11 alone for \$42.95.

### User Group Offers - Books and Magazines

**Pearson Education** Products including Prentice Hall Professional, Addison-Wesley Professional, IBM Press, Exam Cram, Que Publishing, and Cisco Press. Get 35% off list price by purchasing directly from the publisher combo site: [www.informit.com/join](http://www.informit.com/join). Sign in or create an account. Enter the membership code “USERGROUP” (all caps). Select your items and check out. You are required to register and apply the code once, but you must be logged in to receive the special pricing.

**O’Reilly Books** - Get **40% off** all books and videos from O’Reilly, Microsoft Press, Pragmatic Bookshelf, and SitePoint, or 50 % off books you purchase directly from O’Reilly. Just use code DSUG when ordering online, [www.oreilly.com/store/](http://www.oreilly.com/store/), or by phone, (800) 998-9938. Free ground shipping on orders \$29.95 or more in the US. If for any reason you are not completely satisfied with your purchase, you can return it to O’Reilly and get your money back; see [www.oreilly.com/oreilly/cs/guarantee](http://www.oreilly.com/oreilly/cs/guarantee). A return shipping label is included with every direct purchase and directions are posted online in case you misplace it.

**Peachpit Press Books Discount** - Get **35% off** by joining the Peachpit Club. Use the following hyperlink to sign up: [http://memberservices.informit.com/my\\_account/login.aspx?partner=52](http://memberservices.informit.com/my_account/login.aspx?partner=52) to sign up as a member. User group members should note that once you have become a Peachpit Club member, you might use your user group coupon code ON TOP of the permanent savings you earn as a member of the club.

## Consignment Table

The NOCCC Consignment Table in the lobby of Irvine Hall **will** be available during the October 2013 meeting. It is open on even months, the same as the E-Waste collection. The regulations are:

- 1) Only current members can place items for sale, but non-members are welcome to purchase items from the table. This is a great place to get some money for your surplus computer items, and help the NOCCC at the same time.
- 2) The consignment table operates on a 90/10% basis — with the owner getting 90%, and the Club treasury 10%.
- 3) **Fill out a Consignment Table User List, which is available on the NOCCC web site and item tags for each item at the table.**

The user list and each tag must contain:

- a) Seller's name
  - b) Seller's NOCCC membership number
  - c) Item name and description
  - d) Item asking price
- 4) The seller may pick up all items and/or money at any time, but no later than 2p.m. on the day of sale. Any items and/or money not picked up by 2 p.m. will become the property of NOCCC and will be subject to disposal at the Club's discretion. The club has no storage room available for unsold items.
- 5) NOCCC is NOT RESPONSIBLE in any way for items bought and/or sold at the Consignment Table. Each item is placed and sold on an AS-IS BASIS.

## E-Waste

California disposal laws have made it illegal to put monitors and computers in the regular trash. Omni Technics, Inc. **will** be at our regular meeting in October to collect E-Waste. They come **on even months**, so bring your "junk" this month. Call (562) 627-1910 or check their web site for more information:

<http://www.ca-recycle.com/>.

## NOCCC Officers

The area code for the following phone numbers is 714 unless noted.

### President

Dr. Don Armstrong ..... 773-1187 ..... [president@noccc.org](mailto:president@noccc.org)

### Vice President

**OPEN**

### Secretary

Steven Breitbart ..... 486-3070 ..... [secretary@noccc.org](mailto:secretary@noccc.org)

### Treasurer

John Heenan ..... 998-7660 ..... [treasurer@noccc.org](mailto:treasurer@noccc.org)

### Directors

Tia Christian ..... 583-0404 ..... [lwilliams\\_00@yahoo.com](mailto:lwilliams_00@yahoo.com)

Dallas Hazleton ..... 992-4922 ..... [ghazleton4@dslextreme.com](mailto:ghazleton4@dslextreme.com)

Larry Klees ..... 394-1870 ..... [larryklees@yahoo.com](mailto:larryklees@yahoo.com)

Ben Lochtenbergh ..... (949) 653-2545 ..... [bal@msn.com](mailto:bal@msn.com)

Richard Miller ..... 309-1504 ..... [rrrmil@gmail.com](mailto:rrrmil@gmail.com)

Gerry Resch ..... 772-6667 ..... [gerry@gerryresch.com](mailto:gerry@gerryresch.com)

Jim Sanders ..... 544-3589 ..... [jsanders@ligasmicro.com](mailto:jsanders@ligasmicro.com)

Terry Dickson ..... [augiepool@gmail.com](mailto:augiepool@gmail.com)

### Editor

Steven Breitbart ..... 486-3070 ..... [secretary@noccc.org](mailto:secretary@noccc.org)

### Webmaster

Rudy Lauterbach ..... 529-5730 ..... [rblauter@cs.com](mailto:rblauter@cs.com)

## Volunteers, Committees, and Projects

### Consignment Table

Richard Miller ..... 309-1504 ..... [rrrmil@gmail.com](mailto:rrrmil@gmail.com)

### Raffle Leader

Gerry Resch ..... 772-6667 ..... [gerry@gerryresch.com](mailto:gerry@gerryresch.com)

### Helpline

**OPEN**

### Membership Database

John Heenan ..... 998-7660 ..... [treasurer@noccc.org](mailto:treasurer@noccc.org)

### Membership Chairman

Ben Lochtenbergh ..... (949) 653-2545 ..... [bal@msn.com](mailto:bal@msn.com)

### SIG Coordinator

Dallas Hazleton ..... 992-4922 ..... [ghazleton4@dslextreme.com](mailto:ghazleton4@dslextreme.com)

### Programs/Speakers Coordinator

**OPEN**

### Public Relations Chairperson

Tia Christian ..... 583-0404 ..... [lwilliams\\_00@yahoo.com](mailto:lwilliams_00@yahoo.com)

### University Liaison

Dr. Don Armstrong ..... 773-1187 ..... [president@noccc.org](mailto:president@noccc.org)

**Chapman U. Public Safety Office (Security) (714) 997-6763**

**For opening locked rooms, lost and found and other problems**

## NOCCC Help Volunteers

The **Help Line** is in the true spirit of the NOCCC, which is to help others to learn more about computers. The following is a list of Help Line subjects that an NOCCC volunteer is able to help you deal with. E-mail Steven Breitbart at [editor@noccc.org](mailto:editor@noccc.org) with additions, deletions, or corrections. Most volunteers prefer being contacted by e-mail. Mention **NOCCC** in the Subject line.

Apple II	Gerry Resch	714-772-6667	<a href="mailto:gerry@gerryresch.com">gerry@gerryresch.com</a>
Corel Draw	Larry Klees		<a href="mailto:larryklees@yahoo.com">larryklees@yahoo.com</a>
Digital Photography	Larry Klees		<a href="mailto:larryklees@yahoo.com">larryklees@yahoo.com</a>
Excel	Gerry Resch	714-772-6667	<a href="mailto:gerry@gerryresch.com">gerry@gerryresch.com</a>
GPS Navigation	Bob DeWolf	714-879-8269	<a href="mailto:rsdewolf@adelphia.net">rsdewolf@adelphia.net</a>
Linux	Bob Palmer	714-749-0385	<a href="mailto:bpalmer@rccauto.com">bpalmer@rccauto.com</a>
Lotus 1-2-3	Gerry Resch	714-772-6667	<a href="mailto:gerry@gerryresch.com">gerry@gerryresch.com</a>
Microsoft Office	John Heenan	714-998-7660	<a href="mailto:treasurer@noccc.org">treasurer@noccc.org</a>
PC Hardware	Jim Sanders	714-544-3589	<a href="mailto:jsanders@ligasmicro.com">jsanders@ligasmicro.com</a>
Photo editing & Pshop	Larry Klees		<a href="mailto:larryklees@yahoo.com">larryklees@yahoo.com</a>
QuickBooks - all ver.	Linda Russell	909-949-4930	<a href="mailto:qbqueen@verizon.net">qbqueen@verizon.net</a>
Tcl/Tk & UNIX	Bob DeWolf	714-879-8269	<a href="mailto:rsdewolf@adelphia.net">rsdewolf@adelphia.net</a>
Windows 7, Vista & XP	Jim Sanders	714-544-3589	<a href="mailto:jsanders@ligasmicro.com">jsanders@ligasmicro.com</a>
Windows 9X & XP	John Heenan	714-998-7660	<a href="mailto:treasurer@noccc.org">treasurer@noccc.org</a>
WiFi & Networking	Jim Sanders	714-544-3589	<a href="mailto:jsanders@ligasmicro.com">jsanders@ligasmicro.com</a>

Do you want to be an NOCCC Help Volunteer and assist other members with computing subjects that you know well?  
**If so, please contact [editor@noccc.org](mailto:editor@noccc.org).**

## NOCCC SIG Leaders

SIG	BLDG	RM.	TIME	LEADER	E-MAIL	PHONE
Linux for Desktop/Admin .....	Science	131..	9:00/10:30...	Bob Palmer* .....	<a href="mailto:bpalmer@rccauto.com">bpalmer@rccauto.com</a>	(714) 749-0385
Beginner's Digital Photography ...	Science .....	127 .....	9:00 .....	John Krill .....	<a href="mailto:noccc.bgphotosig@gmail.com">noccc.bgphotosig@gmail.com</a>	(949) 497-8658
Visual Programming .....	Science .....	111 .....	9:00 .....	Anson Chapman .....	<a href="mailto:chapmanAnson@gmail.com">chapmanAnson@gmail.com</a>	(909) 860-9515
Exploring New Technology .....	Science .....	109 .....	9:00 .....	Ben Lochtenbergh .....	<a href="mailto:bal@msn.com">bal@msn.com</a>	(949) 653-2545
Apple Devices .....	Science .....	127 .....	10:30 .....	Rick Thues .....	<a href="mailto:imentor@mac.com">imentor@mac.com</a>	(714) 728-3224
Word, Excel, & Outlook .....	Science .....	306 .....	9:00 .....	Tia Christian .....	<a href="mailto:lwilliams_00@yahoo.com">lwilliams_00@yahoo.com</a>	(714) 263-6105
Mobile Computing .....	Science .....	109 .....	10:30 .....	Ben Lochtenbergh .....	<a href="mailto:bal@msn.com">bal@msn.com</a>	(949) 653-2545
VBA for Applications .....	Science .....	306 .....	10:30 .....	Bob Dickson .....	<a href="mailto:robertbdickson@socal.rr.com">robertbdickson@socal.rr.com</a>	(714) 539-1304
Advanced Digital Photography ...	Science .....	127 .....	10:30 .....	Larry Klees .....	<a href="mailto:larryklees@yahoo.com">larryklees@yahoo.com</a>	(714) 879-7962
Understanding OS's .....	Science .....	111 .....	10:30 .....	Charlie Moore .....	<a href="mailto:mooreca@roadrunner.com">mooreca@roadrunner.com</a>	(714) 529-9071
Microsoft Access .....	Science .....	306 .....	12:00 .....	Bob Dickson .....	<a href="mailto:robertbdickson@socal.rr.com">robertbdickson@socal.rr.com</a>	(714) 539-1304
PC Q&A .....	Irvine Hall .....		10:30/12:30 ...	Jim Sanders .....	<a href="mailto:jsanders@ligasmicro.com">jsanders@ligasmicro.com</a>	(714) 544-3589

**Please report SIG changes to [editor@noccc.org](mailto:editor@noccc.org),**

**\*Contact for Linux SIGs**

**Contact the SIG leaders by e-mail, preferably, rather than by telephone.**

## Trouble Shooting Your PC

*By Andy Johnson, NOCCC*

Seemingly out of the blue last week I received a notice that there was a new release for SKYPE, and would I like to install it. Of course I clicked on the accept button. The upgrade started its routine. About the third screen in it asked if I would like to install BING as my new search option and then make MSN my new home page for all browsers. Clicking the NO button I immediately received an ERROR Message 1601: Windows Installer is not available. WOW, it was refusing Bing, and the new home page, MSN, was causing this error?

Researching the problem, I found out that you have to go into SERVICES.MSC to check whether the status of Windows Installer is set to Disable.

1. Click **Start**, type **services.msc** in the start search box and press enter.
2. In the **Services (Local)** list, right click **Windows Installer**, then click **Properties**.
3. If the **startup type** is set to a value of **disable**, select the **Manual** option from the **Startup type** drop-down list.
4. Click on **Start** button below the heading **service status** and click **OK**.

After going through the above routine, I found that the Windows Installer was in fact set to disable and I changed it to manual and saved it. I then rebooted and Skype was installed without any hesitation.

## Installing a Western Digital TV Live Hub

*By Andy Johnson, NOCCC*

First of all you need an Internet connection fairly close to your television set so that you will have access to all that the Internet has to offer.

I decided to use a Trendnet Powerline Kit (TPL-303E2K) a two unit, 200mb/sec kit. One device plugged in near the Router and the other near the TV in the living room. I am using the electrical wiring in the house as my home network. All I then needed was a CAT-5 jumper at each end to complete the connection.

After installing the Trendnet and Western Digital Software on my PC I opened up the WD Link software and found the TV Live Hub and mapped it to my PC as drive M, which is a 1TB HDD. Now anytime I download any videos from the net, I can save it to that drive and then view it later on the large screen. So far it seems to be able to play most all of the formats I have uploaded to it.

As long as you have an account with Netflix you can log in to your account through this hub connection. I tried to do this, but

was stymied using the Remote keys to get Alpha characters to enter my login name. The manual said to press any combo key rapidly two times to bring up an on-screen keyboard. After two hours of futile attempts I called Western Digital Support to get help. Oh yeah, that was changed a while back to a two-key combination. The Option key plus the D key will promptly bring up an on-screen keyboard that you can then use to log into your account. I also found out that you can plug a Keyboard into one of two USB inputs on the Hub itself to use for logins and other navigation purposes.

You can even log into YouTube or Facebook as well. Other services available beside Netflix are Hulu Plus, Vimeo, Cinema Now, Pandora, Flickr and many others. Most are movie sources, both new and old, as well as old TV shows. Some channels are devoted to music of all types only.

## Create a System Repair Disk For Windows 7

*By Andy Johnson, NOCCC*

This is different from a system restore in that it does not wipe the disk clean, reinstall Windows and give you a factory fresh PC.

Type backup in the search box, then click the Create a System Repair Disk on the left side panel selections. You will be asked to input an administrator password or to confirm the action. This will launch the Create a System Repair Disk Wizard which will walk you through the process. It's possible that you'll be asked to insert a windows installation disk at some point. If it does, then your PC does not have the required files to create a repair disk.

On the Wizard, select the optical drive you want to use and insert a writeable disk, and click create disk.

Be sure to label it as System Repair Win 7 and especially whether it is 32 or 64 bit depending on the PC that created the disk.

As this is a bootable disk, it can be used when your PC becomes unbootable. When this occurs place your Repair disk in the optical drive and turn on the PC. You should be prompted to press any key to boot from the CD. (If not, you will have to go into your BIOS and change the boot sequence.) The first screen you see is labeled System Recovery Options, with five choices:

1. Start Up Repair
2. System Restore
3. Windows Complete Restore
4. Windows Memory Diagnostic Tool
5. Command Prompt.

With choice 1 you will be able to start your trouble shooting and be able to make repairs to get going again avoiding a drastic System Restore.

---

## Got Windows 8? Then Get Start8

---

By Tom Kuklinski, President, Computer Users of Erie, PA

April 2013 Issue, Horizons, [www.cuerie.com](http://www.cuerie.com)  
tkuklinski (at) gmail.com

Some reviews of Microsoft's Windows 8 have been brutal. I have been using Windows 8 since December 2012. It is on a desktop and does not have a touch screen. It works well. I have not experienced a crash to date.

Overall, I do like Windows 8. Do I prefer it to Windows 7 or XP? Yes, I do! That is a powerful statement. Here is why.

Windows 8, like Windows 7 is pleasant to use. I find it overall to be aesthetic in appearance. It is like having two operating systems. The so called Metro-Modern Start Screen consists of blocks that contain your programs. There is no START BUTTON like in previous Windows versions. This look was made to conform to hand-held devices like phones and tablets. These devices use touch screens and this layout works. However, when using a traditional Windows 7 desktop, it almost becomes useless. There is no point to have it other than to remain consistent in appearance between hand-held devices and your desktop or laptop. Microsoft made one of these Metro-Modern Start Screen program blocks to access the good old traditional desktop of by gone Windows versions. EXCEPT, there is no START button like previous versions of Windows.

Some of the apps that are made for the Metro-Modern look may work different that you would expect on a laptop or desktop application. For instance, Internet Explorer 10 when in the Metro-Modern mode will be in a minimalist mode. You will not have the full robust appearance that you would be used to having if launched from a Windows 7 desktop. However, Microsoft did include the full version of Internet Explorer 10 in the Windows 8 desktop. Sounds confusing. It is, until you become accustomed to this. However, this difference really is not great. You can choose to stay in the familiar traditional Desktop mode that looks like Windows 7 and not visit the Metro-Modern Start Screen very much.

However, one great issue exists. This single issue may be the problem as to why Windows 8 has not been too successful. The START Button at the lower left corner of your screen is missing. Microsoft purposely left this button out. So if you use Windows XP, Vista or 7, you are familiar with the Start button and rely on it for just about everything you do. Picture it gone. Now you see the problem.

It is this anomaly that may have caused the negative reviews and caused slow sales of Windows 8. So Microsoft, wake up and give us that START BUTTON back.

Until Microsoft does include the Start Button, here comes a company that has been around for thirty years. It is Stardock. This company created a program called START8. The purpose of this program is to put the good old Start Button back on the Windows 8 Desktop screen and function as before.

START8 costs a mere \$4.99. To me this is a bargain. Lets take a look at this START8. You need to download it from [www.stardock.com](http://www.stardock.com). Then install it. Simple and done. You can customize this START. You can choose a STYLE. It can be the traditional Windows 7 theme or custom to your preference. You may choose a Windows 8 style. You may have translucency, flag look START button or customize.

You also can choose, Large Icons, Show Recently used applications, Open sub Menus, create shortcuts, show Windows 8 Modern User Interface, control some Window 8 features – on and on.

That is about all it does. It is cheap and works well. This is one of those programs that is so obvious. In fact, this one program may actually increase sales of Windows 8.

I recommend this to anyone that uses Windows 8. Thank You Stardock.

---

## Internet Alerts Can Keep You Informed

---

Sandy Berger, *CompuKISS.com*

[www.compukiss.com](http://www.compukiss.com)  
sandy (at) compukiss.com

How would you like to know every time your name is mentioned on the Web? Or when there is a breakthrough on a disease that you are following? Or when your favorite actor is starting in a new movie? This is all possible with automated Internet alerts. Read this to see how it works.

Internet alerts are available by many different Internet services. The Weather channel at [www.weather.com](http://www.weather.com) has free alerts that will give you daily weather alerts as well as alerts for allergens like pollen and also alerts for severe weather. Other alerts will keep you informed of the weather on school days and give warnings for snow and rain. You can apply several customization options such as the time of the alert and the severity that triggers the alert. You can get alerts sent by e-mail and/or text to a cell phone.

Many news stations also have alerts regarding news, sports and weather. One of my local North Carolina stations, WRAL ([www.wral.com](http://www.wral.com)) even has an app that uses GPS to alert you to severe weather no matter where you travel as long as you have your cell phone turned on. While most other alerts are free, WRAL charges \$8 a year for their GPS-based alerts. Check your local news stations for news alerts.

The granddaddy of all alerts, Google Alerts, is a very useful one that you should be aware of. This is one of Google's powerful tools that is completely free. You can use Google Alerts to keep track of anything on the Web. Just surf over to <http://www.google.com/alerts> and enter a search query. Then choose your options. You can control how often you get alerts (as it happens, once a day or once a week), the type of Web coverage that triggers an alert (news,



blogs, video, discussions, books, or all of these), and you can also choose only the best results or all results. Enter your e-mail address and your alerts will start. You can change or remove an alert at any time. Once you start using Google Alerts, you will be surprised at the results.

Most people start with creating an alert with their own name. My “Sandy Berger” alert tells me when any news article or blog mentions my name. Of course, it also gives me results for the other Sandy Berger. You know -- that guy from the Clinton administration who stuffed documents from the National Archives into his pants. Unless you have a very unusual name, you can expect to get news of others with the same name. That’s not all bad. In fact, it can be very interesting.

The Google Alerts can be wonderful if you are following the news about a certain item. For instance, they are wonderful if you are interested in following a certain disease, medical condition or treatment. You can use Google Alerts to follow any current event or any specific public figure, actor, or personality.

If you are a transplant and want to follow the news from your old hometown, this is a perfect way to do it. Just enter the name of your old city and state in the search terms. If you want to be more specific, you can just enter the zip code. This will give you results directly from your old neighborhood.

When you set up a Google Alert, you may want to limit the results to just the best results and once a day. If you let Google give you all the results as they happen, I can assure you that you will be inundated with email.

You are sure to find many different ways to use Google Alerts. In fact, it is good to play with the Alerts a little to get just what you want. Like any Google search, you can enter as many search terms as you like to narrow the results. You can put names in quotes to get exact matches.

Be creative with your alerts. You can have Google search for coupons for your favorite restaurant. You can use it to follow a company whose stock you may be interested in purchasing. You can use it to follow an item that you want to purchase.

## Word and Excel Tips

Word Tips and Excel Tips are now available for menu driven and ribbon driven versions of Word and Excel. Please let me know if you prefer menu or ribbon tips. Send an email to [editor@noccc.org](mailto:editor@noccc.org), with the Subject as follows:

**NOCCC Word/Excel Tips–[Menu, Ribbon, Both]**  
Just pick menu, ribbon, or both. If you have other comments, fine too.

## Excel Tips - Changing Gridline Color

By Allen Wyatt (last updated June 22, 2013)

Please Note: This article is written for users of the following Excel versions: 97 | 2000 | 2002 | 2003. If you are using a later version (Excel 2007 or later), this tip may not work for you.

The gridlines help you track information on the screen easier and to locate cells quickly. Normally the gridlines are shown in black, but you may want to make them some other stylish color. If you want to change the gridline color, follow these steps:

1. Choose Options from the Tools menu. You will see the Options dialog box.
2. Click on the View tab. (See Figure 1.)

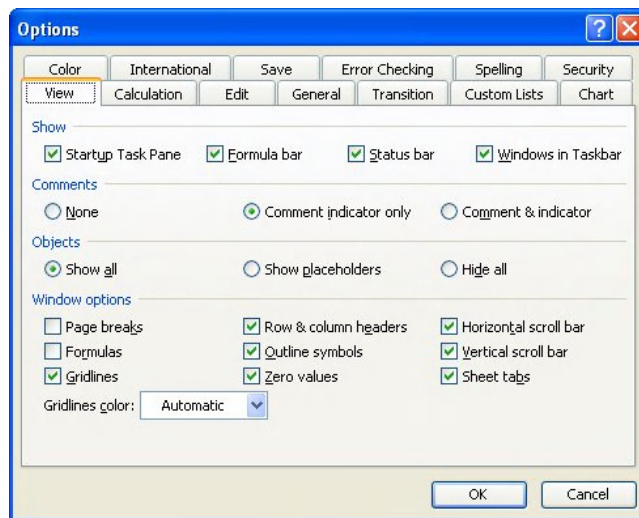

Figure 1. The View tab of the Options dialog box.

3. Use the Color drop-down palette to select a color for your gridlines.
4. Make sure the Gridlines check box is selected.
5. Click on OK.

You can specify different gridline colors for each worksheet in a workbook.

ExcelTips is your source for cost-effective Microsoft Excel training. This tip (2736) applies to Microsoft Excel versions: 97 | 2000 | 2002 | 2003

# Word Tips – Applying Bullets from the Keyboard

By Allen Wyatt (last updated June 15, 2013)

Word includes a handy-dandy tool on the toolbar that allows you to add bullets to a paragraph in a jiffy, and just as easily remove them. Unfortunately, there is no just-as-easy way to do the same thing using the keyboard.

If you are bound and determined to use the keyboard to apply (and remove) bullets, there are a couple of things you can look at. The first is to use styles and define keystrokes that apply your styles. There are numerous other benefits to using styles, but most of those have been covered in other WordTips.

Closely related to this approach are two built-in shortcuts provided by Word. If you press Ctrl+Shift+L, Word is supposed to automatically apply the predefined List Bullet style to your paragraph. Unfortunately, there are many reports of this not working reliably. (On some systems it won't apply the style, even though the shortcut is still "attached" to it.) To remove bullets, you could also use the Ctrl+Shift+N shortcut, which applies the Normal style.

While these may work for what you want done, they don't take the same approach to formatting as the Bullets tool on the toolbar. If you want to have that same functionality from the keyboard, you must customize your keyboard. You do this by displaying the Customize Keyboard dialog box. (See Figure 1.) How you display the dialog box depends on the version of Word you are using.

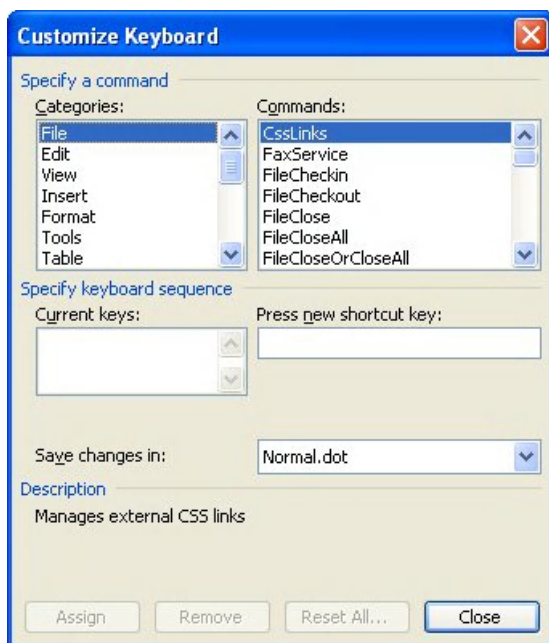

Figure 1. The Customize Keyboard dialog box.

- If you are using a version of Word prior to Word 2007, choose Tools | Customize | Keyboard button.

- If you are using Word 2007, click the Office button and then click Word Options. In the Word Options dialog box, click Customize and then click the Customize button.

Once the Customize Keyboard dialog box is displayed, follow these steps:

1. In the Categories list, choose Formatting.
2. In the Commands list, choose FormatBulletDefault.
3. Click in the Press New Shortcut Key box.
4. Press the keystroke you want to use to apply bullets. Alt+B is a good choice, since it is not in use on a default Word system.
5. Click on Assign.
6. Click on Close to dismiss the Customize Keyboard dialog box.
7. Click on Close to close the Customize dialog box.

Now, whenever you press the keystroke you chose in step 4, it is the same as clicking on the Bullets tool. Press the keystroke again, and the bullets are gone. (Of course, you can also press Ctrl+Q to remove the bullets by returning to the default paragraph formatting.)

WordTips is your source for cost-effective Microsoft Word training. (Microsoft Word is the most popular word processing software in the world.) This tip (87) applies to Microsoft Word versions: 97 | 2000 | 2002 | 2003

## Online Reputation Protection

By Steven Breitbart, NOCCC Orange Bytes Editor

Finally, the word is getting out via non-geek sources that all of us need to protect our online reputations. Consumer Reports Money Adviser, August 2013 issue, mentions this subject in two articles. In an introductory piece, the editor had an experience where she realized how online information could be used to develop an opinion about someone you haven't met.

The later article lists steps you can take to protect your reputation online. The most innovative step was to buy the web address of your name even if you never intend to put up a website.

One item I didn't understand for this topic was the advice to start a blog. One item I appreciated was the steps to go through to get bad information removed and when to get a lawyer involved.

# Reviews Editor's Corner

## Products Available For Review

The NOCCC regularly receives copies of books and sometimes software from vendors for our review. We can also request specific products for you to review. These reviews are published in this newsletter, the

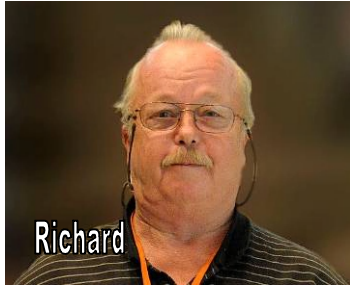

Orange Bytes. Then, you get to keep the book or software. If you are interested in doing a review, please send an e-mail to [reviews@noccc.org](mailto:reviews@noccc.org) and provide your membership number, phone number, and e-mail address. You can pick up the product from Richard Miller in the lobby of Irvine Hall between 9 A.M. and Noon at the regular monthly NOCCC meeting.

### Note to Reviewers

- ❖ You have 2 months to submit a review. Due-cause time extensions must be requested from the Reviews Editor.
- ❖ You must leave a security deposit (check, credit card number, or cash equal to the product's list value.), returnable upon our receiving an acceptable review.
- ❖ If you decide to return the product without reviewing, there is a \$2 penalty after the first month and a \$5 penalty after the second month.
- ❖ Guidelines for preparing your review are spelled out at <http://www.noccc.org/>. Click News, Site Tech Info.

## Books

### Social Networking & Internet

**New: On Top of the Cloud: How CEO's Leverage New Technologies to Drive Change & Build Value Across the Enterprise** – Authored by Hunter Muller from John Wiley & Sons. MSRP=\$65.

**Mom Blogging for Dummies** – Learn how to set up your blog and use it to sell your products & services. From Wendy Piersall from Wiley. MSRP=\$25.

**The Digital Afterlife** – How to secure your digital assets for your heirs. By Evan Carroll & John Romano from New Riders. MSRP=\$25.

**The New Technology Elite** – By Vinnie Mirchandani. From Wiley. MSRP=\$50.

### Digital Photography & Design

**Photoshop CS6 Quick Start Guide** - By Weinman & Hove. From Wiley. MSRP=\$40.

**New: The Photoshop Elements 10 Book for Digital Photographers** – Authored by Scott Kelby & Matt Kloskowski from New Riders. MSRP=\$50.

**New: Adobe Photoshop Elements 10 Classroom in a Book** – The official training workbook from Adobe Systems. From Adobe Press/Peachpit Press. MSRP=\$45.

**The Portrait Photography Course** – Principles, practices & techniques. By Mark Jenkison, from Peachpit Press. MSRP=\$40.

**Professional Portrait Retouching Techniques for Photographers using Photoshop** – Learn how the pros do it. By Scott Kelby, from New Riders. MSRP=\$50.

**Canon PowerShot G12** – From snapshots to great shots by Jeff Carlson from Peachpit Press. MSRP=\$25.

**Adobe In Design CS5 Classroom in a Book** - By Olav Kvorn & David Blatner. From Peachpit Press. MSRP=\$55.

**Adobe "Real World In Design CS4** - The book covers the waterfront in Adobe's 'New Design Suite.' By Kvorn & Blatner. From Peachpit Press. MSRP=\$50.

**New: The iPhone Book** – By Scott Kelby & Terry White. From Peachpit Press. MSRP=\$25.

**Picture Perfect Practice** – By Robert Valenzuela. From New Riders. MSRP=\$45.



# Product Review

## USB3 Front Bay Interface Review

Review by Jim Sanders, NOCCC

Akasa AK-ICR-17 3.5" USB 3.0 Memory Card Reader w/

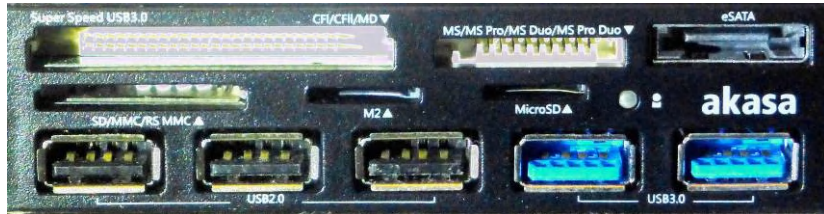

eSATA and USB ports review.

I searched for this type of front panel product to replace an older 3.5" bay product with fewer features and a card reader that couldn't read the SDHC cards, much less the SDXC cards. The Akasa AK-ICR-17 product provides more capability in that form factor than any other product I found. Being careful, I searched for reviews and to my dismay found a number of negative reviews. But after reading them carefully, and in a number of cases, reading between the lines, I dismissed most of them. Most of the problem reviews were the result of two things: uneducated buyers and POOR documentation from the manufacturer.

The documentation that comes in the box, which Akasa has the audacity to refer to as a "USER Manual," is on one side of a folded 11 x 14 inch sheet of paper. The instructions, in five languages, along with five drawings, are all on that single page. To be fair, I have to concede that I understood the information that was presented in the "USER Manual." But after 3 decades of being a PC Consultant, I am very familiar with not only the verbiage and images used, but with the unstated requirements that they imply. In the above image you have: (e) 2 port, 20 pin, male, USB 3.0 motherboard connector. One port for the card reader. One port for one of the female front panel connections. (f) USB3.0 male 'A' connector (this is on a long cable to be plugged into a back panel port). (g) 4 pin Molex power connector/extender. (h) 10 pin USB 2.0 motherboard connector.

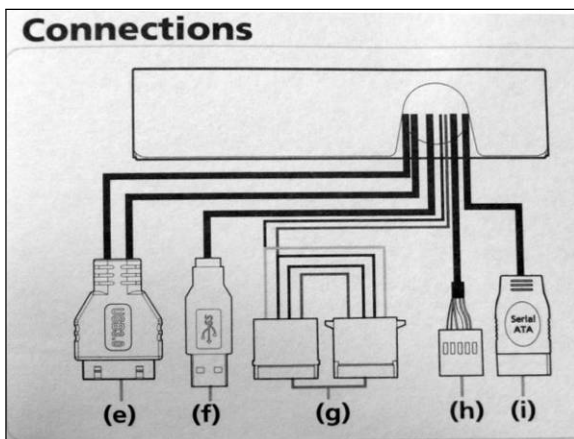

(i) Serial ATA (SATA) cable.

In a few of the negative reviews, it almost sounded like the buyer concluded that if he had an open 3.5" bay, it would work in his computer. Wrong! Akasa's electrical engineering, mechanical engineering, and manufacturing departments all did a great job. The person in charge of Documentation and probably in Marketing, should be fired.

This product was designed for a current or at least late model, higher end, motherboard. Preferably, one introduced in the last two years. Why? Because it requires that your motherboard has a (now standard) 20 pin USB 3.0 header to plug its 20 pin USB 3.0 cable into, or it CAN'T work properly. The SATA cable and the USB 2.0 cable should not be a problem for most newer computers. The 4-pin Molex power cable should be no problem for most systems, but some chintzy OEMs save a few pennies by only providing the SATA type power cables. You can buy SATA to Molex power cable adapters. The other USB 3.0 cable is probably a design compromise for motherboards that only have one 20 pin USB 3.0 header. It is a long cable that is intended to be run out the back of the case and plugged into a back panel USB 3.0 connector. It only connects to the Akasa front panel USB 3.0 female connector that is next to the edge of the bay. So if you don't use that cable, the right hand connector is not functional. This is kind of funky, but at least makes a back panel connection more accessible, and it works. However, you should keep in mind that it adds about 2 feet of cable to your connection. My Asus P8Z77-V Pro motherboard has two 20 pin USB 3.0 headers, but I have to buy a 20 pin USB 3.0 header to 2 regular USB 3.0 female connectors adapter to avoid running the cable out the back as I am currently doing. If you do a Google image search for "Motherboard 20pin Header Female to Dual USB 3.0 Type A-Female Adapter Connector" you will see quite a few. It is best to keep the length of any USB cable as short as possible. So I have ordered one of the taller 'all one piece molded together' types instead of the short cable variety. If you really wanted to do it "right," you would cut and re-solder that cable to just long enough to reach the adaptor. Check your computer case for available space; you may have to use the short cable type of adaptor.

The Akasa AK-ICR-17 mounted in the 3.5" bay easily. Routing and connecting all the cables was tougher. The USB 3.0 cables are relatively large (a good thing) and stiff. It took awhile to unfold the cables from their tie wrapped shipping configuration and get them straight. I then had to dress their path to be neat as possible. My Asus P8Z77-V Pro motherboard provides all the necessary connections and when the computer was powered up, every function of the unit tested OK.

If all of the above information, and more, were included in Akasa's documentation, I would give the unit 5 stars. But the documentation is truly POOR. However, in my system, it works great and does all that I hoped for. With caveats, recommended.

---

# Windows 7 for Dummies, Pocket Edition

By Steven Breitbart, NOCCC

As editor of the orange bytes, I thought I might have to make the issue smaller for postal reasons. As a result, I thought I would do a book review of a small book. Windows 7 For Dummies, Pocket Edition is such a book. I bought this book somewhere; it's not from the reviews table.

Windows has an incredible number of features, I know about a lot of them. But I wondered if this pocket edition could teach me something I didn't know. I was not disappointed.

In fact, I was impressed. There is a lot of great information in this book. It was written for people to check when they had a specific problem. The idea is to teach you what you need to know and let you get back to work. That is accomplished by consulting the Table of Contents – there is no index. The book was not written for people to read from beginning to end.

Six icons are used in the book to indicate warnings, new features of Windows 7, differences from Windows XP, important points, technical information and “juicy information.” The book describes the seven different types of Windows 7. Six are available in the United States. The seventh type, for Europe, comes without Internet Explorer. Windows 7 runs better on laptops and is an easy upgrade from Windows Vista.

Windows 7 For Dummies, Pocket Edition explains many features including indexing and searching your hard drives, flash drives, folders and files. It covers the library system very briefly, the user account control, which has been toned down from Windows Vista, Windows backup, changing Windows' appearance. It covers WordPad, character map, the Aero Themes, the Flip 3D view of open windows, arranging and grouping files, the Control Panel and many of the items in it, such as adding a mouse, printer, scanner or camera and adding, removing or changing programs including Windows 7 itself.

There is a chapter on getting support, help and troubleshooting. The last chapter (actually called Part VII) is “Almost Ten Things You'll Hate About Windows 7 (And How to Fix Them)” This chapter covers eight common problems, such as a disappearing taskbar.

I didn't know about creating a password reset disk, which is easy; jump lists, which you see by right clicking a taskbar button. This gives you access to recent documents, folders and web sites used by that program. I didn't know you could force Windows to rebuild the index or that the Volume Mixer can adjust the sound for each program. Lastly, I didn't know you could globally rename a group of files as long as you're OK

with all the files having the same name plus a sequence number. It reminded me that I could place an Internet address toolbar on the taskbar.

The book is occasionally informal, exaggerates and is even a bit flippant. For example “cute little windows,” “Fiddling around with user accounts” or “Playing with Programs and Documents,” etc. The book described the number of icons in the Control Panel as “umpteens-zillion.” I have 53 icons in my Control Panel, quite a difference, yes?

There are not too many errors or problems with Windows 7 For Dummies, Pocket Edition. It describes a Windows 7 single click shut down. Sorry, it's really two clicks: the Start button and then the Shut Down button. The book mentions cut or copy and paste before describing how to select text, which seems to me to be backwards. Taskbar buttons do not always show the name of the program they represent. Microsoft Word 2003, for example, shows the *document* name. Taskbar toolbars can be resized, but the handle is three columns of dots, not a vertical line. A few sections are a bit repetitive of other sections. In addition, several things seem to depend on what view setting you were using. Alt-view menu did not work to clear changes made to folders view settings. However, that capability is available in the Arrange by: list of commands, though not all folders show the Arrange by: button.

Windows 7 books seem to be rare at my local stores. I happened to pick up this book some time ago as an impulse purchase. It is one of the best \$5 purchases I have ever made.

*Windows 7 For Dummies, Pocket Edition.* Written by Andy Rathbone. John Wiley & Sons, NJ. Copyright 2010. ISBN: 978-1-118-03795-9. 144 pages. List price \$4.99.

---

## Orange Bytes in Color at the NOCCC Website.

The latest issues of the Orange Bytes (as well as past issues) are available in PDF format, with **color** photographs. There is no user name or password needed. Go to our website: <http://www.noccc.org/>.

# September 1, 2013

## Main Meeting Report

*By Steven Breitbart, NOCCC*

### Club Business

NOCCC President Don Armstrong opened the meeting at 2:00 p.m. He introduced Steven Breitbart, the Editor of the Orange Bytes newsletter to make a few comments.

Steven said that a few months ago he put a short article in the Orange Bytes regarding Word and Excel Tips. These tips are available for the menu driven versions of these programs (Office 2003 and earlier) and ribbon driven versions (Office 2007, 2010 and 2013). He asked people to contact him and state their preference - menu or ribbon. No responses were received, possibly because the email address was listed incorrectly as editor@noccc.com instead of editor@noccc.org. This is typical; we have asked for responses on other issues over the years and usually get no response. Someone replied that if you get no complaints everyone is happy. Steven then asked the audience what their preferences: menu or ribbon tips. A few people said menu, a few said ribbon and some said both. He said he would write another article about this.

Steven said he still needs help producing the newsletter. He asked for people to take over checking the membership benefits, the books that can be obtained for review and the transcribing of the recording of the Main Meeting and the Executive Board meeting (the latter would require a person to attend the Executive Board meetings). Also needed are people to proofread the newsletter.

The Random Access portion of the meeting came next. Larry Margol, a guest at the meeting, wants to get back into programming. He asked if anyone was involved in programming projects. Someone suggested he attend a robotics meeting at Cal State Long Beach. Some other suggestions were made but were inaudible on the recording of the meeting.

After the speaker, Don added some NOCCC pens to the General and Members only raffle. [Editors note: Unfortunately, most photographs of the winners were lost and prior photographs of the winners were used. The captions are correct.]

### Main Meeting Speaker

Don then introduced NOCCC webmaster Rudy Lauterbach. He said that getting the website to do what it does is more difficult than it seems. It is informative, educational and enjoyable. Rudy has a complete background in computers. He has a B.S. in Electrical Engineering from the University of Miami and a M.S. in Engineering from Cal State Northridge. He has worked as a Digital Designer in the aerospace industry (Litton Industries, etc.) and 24 years for Hewlett Packard (hardware and software). After retiring from his day job, Rudy has been teaching web design, programming and Linux at local colleges for eight years. He is now focusing on web site design for fun and amazement.

Rudy started by accessing the website. He said that he wants to address two aspects: How does it work? and How did we get here? He then started describing the features of the web site. There are two menu bars are present near the top of the website. The upper one has links to other web pages, the lower one has drop down menus. The items in most of the drop down menus are also links.

One purpose of the website is to deliver the Orange Bytes newsletter in color. Another mission is to provide information for potential visitors to learn about the club, its location and meeting times. The third mission is to let people know the benefits of joining the club. To that end, several maps, parking information and calendars are accessed from the **Location** and **Calendar** menus.

SIG reports are included in the Orange Bytes newsletter and not directly in the website. However, the last published issue of the Orange Bytes is accessible from the home page via the big red button on the upper right. Previous issues are also available in the website. The three columns on the home page are for news items and the idea is to emulate the look of a newspaper.

The Benefits menu goes to a page that has information about the consignment table **and the form used for submitting items for sale**. Another web page found through the **Dues** menu shows a list of dues and contribution levels. The **News** menu has another way to get to the latest issue of the Orange Bytes and Site Technical Information such as Guidelines for Writing Reviews. Ted Littman, who used to be the Reviews and Orange Bytes Editor, wrote this several years ago, so Steven is now the Editor of the Orange Bytes. Site Technical Information also mentions that sometimes underlined text is a link and other times it is there for emphasis. The way you tell is by hovering you mouse over the underlined word, words or icon and it will change to a hand if it is a link. He demonstrated this difference.

Rudy talked about Internet browsers and Internet Explorer's Compatibility View. It helps when a website is designed for an older browser. In addition, browsers cache web pages for quicker access, so you should refresh the page by either clicking on the circular Refresh icon at the top of the Window, click on Refresh in the View menu or use F5. He didn't know how often a browser would automatically refresh a site. We have all heard of the major Internet browsers such as Internet Explorer, Firefox, Safari, Chrome and Opera. There are actually around 80 browsers, which are listed on a page accessed from the Site Technical Information link.

Rudy then described the **Login** Page for NOCCC members only. The Login Page is easily accessed from the link at the top right of the home menu bar. He uses cookies to remember that you are logged in. A cookie is a short text file, hidden away from you, living on your computer, that a domain host can write to if you allow it. However, there are first party cookies and third party cookies. He recommended that you inhibit third party cookies. The cookie lifetime has been set for 24-hours.

HTML 5 was released last year and is now being implemented in many browsers. Prior versions did not have the capability web developers wanted. It has features such as graphics

capability. He created an animated icon for the club website (accessed through the Site Technical Information page) that rotates if you have HTML 5. If not, there's just a line of text. [Editor's note: If you have a modern browser and you want to see the line of text, try Compatibility View.] Steven asked if a browser would indicate that it is using HTML 5. Rudy said he hadn't seen a browser that revealed that information. HTML 5 has provided a graphics tool called Canvas, which is accessible only using JavaScript. JavaScript is becoming the most popular programming language for website development in the world.

More from the **News** menu is a list of Single Board Computers that Rudy put together. Each listing was a link to that brand's website. Rudy had done a presentation on the Arduino at a previous NOCCC meeting. Others listed were Raspberry Pie, Beagle Bone and several referred to as Stamps. Another web page has links to other computer clubs in and near the Southern California area. For example, ORCOPUG, the Orange County PC Users Group, which Rudy has joined.

The **SIGS** menu item shows another page that lists the NOCCC SIGs. The **Archives** menu item provides access to the Orange Bytes newsletter starting with issues in 2002. The different years are presented in the cells of a table. There is a page for a club history. However, that page is almost blank. [Editor's note: If you have information about the club history, share it with someone on the Board.] On another page, Rudy has established a place where members can notify him of good websites. He already has several places listed to get computer advice.

The Old Links page is a massive list of all sorts of links in all sorts of subjects made by members many years before Rudy became involved. He said many of the links are obsolete or broken. We need volunteers to check out each link and let him know if they should be removed. Still, he tried one out at random and it worked. He tried to search the web page but could not find many matches. Another page from the Archives menu provides access to the current NOCCC Bylaws. That page also has a list of charter members from when the NOCCC was formed in April 1976.

The top menu bar Administration menu links to a list of the Officers, Directors, Committees and Projects. The latest President's message is published every month in the Orange Bytes and is not included in the website to minimize redundancy. Finally, there is a disclaimer similar to what appears in the Orange Bytes. The NOCCC is not responsible for the opinions of individual authors, etc.

The About menu has some basic information about the club. A rotating ball is visible. This was made with a GIF file, which can be used for animations. The Sitemap menu item lists most of the myriad files needed to create the club's website. The Contact menu item also lists the Officers and Directors of the club and their contact information.

The Login menu page has two halves. Rudy said that we could disregard the bottom half; it helps him debug the page. You fill in your badge number and the email address that the club uses to send out your Orange Bytes. He demonstrated logging in. That takes you to the NOCCC Members Page, which has some

information about other local workshops and classes. Mostly it lets you select the Member's Forum (the name was changed from Community Bulletin Board because of suggestions at this meeting) where members can post comments. Comments are inserted at the bottom. Then you must submit the comment and refresh the page or click on Re-display Recent Comments File located at the very bottom of the page to see the comment included.

Rudy concluded with the Pastimes menu item. There are several things included: cartoons, games, stories, a humorous list of acronyms and a z-axis test for your video board. Rudy demonstrated the z-axis test, which is several cartoons, stacked and offset from each other. The one you mouse over comes to the top. If it shows up quickly, you have a fast video board. He also demonstrated "The Game of Life," which was recently installed, and consists of squares on a grid that the user picks. The rules to calculate whether a chosen square lives or dies were invented by a mathematician in 1970. The object of the game (I think) is to make the squares last as many generations as possible starting with the smallest amount of squares possible.

An interesting meeting! See you next month.

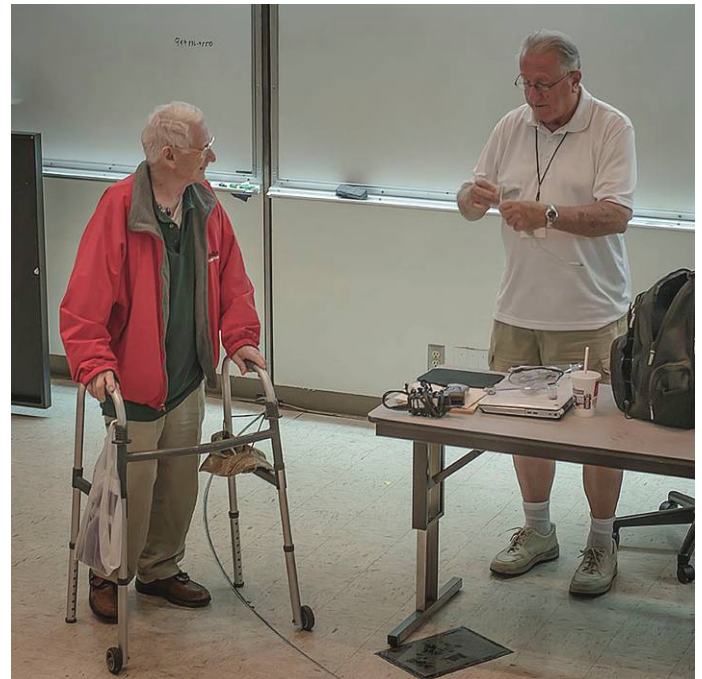

Rudy Lauterbach and Howard Hugger after the meeting

## You could be a raffle winner!

- 1) Buy tickets \$1 each or 6 for \$5
- 2) Remember to bring \$1 or \$5 bills
- 3) Two General raffle tickets for a Lastinger Parking permit
- 4) One members only raffle ticket for wearing a NOCCC Badge and another for wearing a NOCCC shirt

**September 1, 2013 Raffle Winners**  
*Old photos by John Krill, new photos by Larry Klees, NOCCC*



**Bob Dickson (Old photo)**  
*My Passport 500GB Hard Disk for Mac*



**Don Armstrong (Old photo)**  
*Logitech wireless mouse*

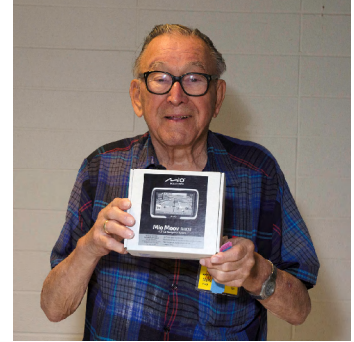

**Martin La Rocque (Old photo)**  
*NOCCC Pen*



**Muriel Fitzsimmons (Old photo)**  
*NOCCC Pen*

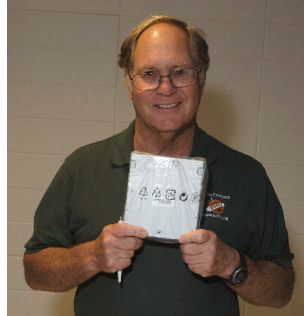

**Terry Dickson (Old photo)**  
*SIIG SonicBuds earphones*



**Gerry Resch**  
*Computer Screw Kit*



**Gerry Resch**  
*Gear Head Retractable Mouse*



**Dallas Hazleton (Old photo)**  
*Magicjack PLUS*



**Steven Breitbart**  
*NOCCC Pen*



**Carl Rau (Old photo)**  
*SIIG SonicBuds earphones*



**Martin La Rocque (Old photo)**  
*Computer Screw Kit*



**Don Armstrong (Old photo)**  
*NOCCC Pen*

\*Most of the photos taken in September were lost due to a technical problem.  
 The *captions* above are correct, the old photos are a few to several months old.



## SIG Meeting Reports

### Apple Products

*By Rick Thues, NOCCC SIG Leader*

The Apple SIG leader is Rick Thues (AKA the iMentor). Rick is a long time member of the Apple Consultants Network. He is an expert Apple consultant and instructor. We discuss all things Apple. Bring your questions and knowledge of Macintosh computers, iPad, iPhone and iPod. Also discussed is Apple software, such as iMovie, iPhoto, iWork and Garage Band. Interest level is everything from beginners to Windows switchers to expert. Bring your iPad, iPhone, Macbook, etc.



Please Park in campus visitor parking areas. Most street parking on the residential side is restricted and if you park there, you will be ticketed.

There is a NOCCC Main Meeting speaker presentation at 2:00 p.m. in the Irvine Lecture Hall which you might want to attend.

At this SIG we THINK DIFFERENT.

Rick Thues - the iMentor®  
[imentor@mac.com](mailto:imentor@mac.com)  
714-728-3224  
[www.theimentor.com](http://www.theimentor.com)  
[www.theimentor.com/theiMentor/Apple\\_SIG.html](http://www.theimentor.com/theiMentor/Apple_SIG.html)

peace

*This SIG meets in Science 127 at 10:30 a.m.*

### Microsoft Office

*Tia Christian, NOCCC SIG Leader*

This session is an open forum for problems incurred using Microsoft **Word**, **Excel** and **Outlook** versions 2003 to 2007 and **Open Office** and their resolutions. Different topics about these four software applications will be discussed during each session.



*This SIG meets in Science 306 at 9:00 a.m.*

### Visual Programming

*Anson Chapman, NOCCC SIG Leader*

This SIG is lead by Anson Chapman and is a continuing discussion group about computer programming using Visual Basic, Visual Basic Script, Visual C, Visual C++ and Visual J++ for Beginners.

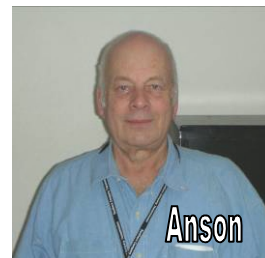

*This SIG meets in Science 111 at 9:00 a.m.*

### Understanding Operating Systems

*Charlie Moore, NOCCC SIG Leader*

This SIG is lead by Charlie Moore and is a continuing discussion group about Operating Systems for computers.

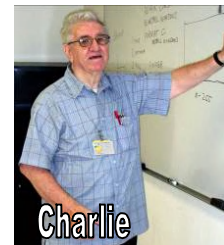

*This SIG meets in Science 111 at 10:30 a.m.*

### Pig SIG Open to All

Meet us outside **Irvine Hall** from about noon to 12:30 p.m. There are several benches where NOCCC people gather, eat and chat. Just look for the member badges, grab a chair and join in!

This is an informal group; so many different subjects are discussed. It's a great opportunity to mix, mingle and network!

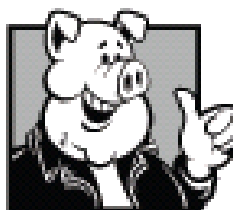

**Free coffee & tea at the October meeting!**

**Donuts are \$1 each**  
**Cookies are 50¢ each**  
**No Freebies!**

# Beginner's Digital Photography

By John Krill, NOCCC SIG Leader

## September Meeting

John wasn't present in September. Larry Klees filled in for John.

## October Meeting

I'm bringing in a new Asus 7-in. tablet and a new device for your TV called Chromecast. Chromecast may not work on the Chapman network. We will see.



## Standard Stuff That Is Always In This Report

If you have a special request for information regarding digital photography let me know. E-mail me using the address listed below.

Check out the SIG BLog for other information and maybe info on what we will discuss at the next meeting.

As always, we will answer any and all questions.

*See you at the next meeting.*

**Note:** I am using a new Web location for the photos I take at the meeting. I now upload the photos I take to Microsoft SkyDrive and Flickr. A link will be put here every month to the folder location with the current month's photos, if any.

SIG BLog: <http://nocccbgphotosig.wordpress.com/>

Email: [noccc.bgphotosig@gmail.com](mailto:noccc.bgphotosig@gmail.com)

*This SIG meets in Science 131A at 9:00 a.m.*

# Advanced Digital Photography

By Larry Klees, NOCCC SIG Leader

## The September meeting

John Krill was away so I filled in for the Beginning Digital Photography SIG. The intent was to have a beginning introduction to a photo-editing program called GIMP (GNU Image Manipulation Program). This is a very powerful program with numerous features. It will run on Macintosh, Windows and Linux computers. After that, the intention was to have more advanced coverage of GIMP in the Advanced Digital Photography SIG. As things worked out, it turned into a single three hour SIG.

As part of the presentation we used a photograph supplied by Howard Philips (one of our members) to demonstrate basic photo manipulation.



The first three steps shown are desirable for nearly every photograph we take. The fourth step is like the cherry on top.

It is often desirable to take a photo as above that can be cropped in a variety of different ways. The first step was to crop the photo for the desired composition.

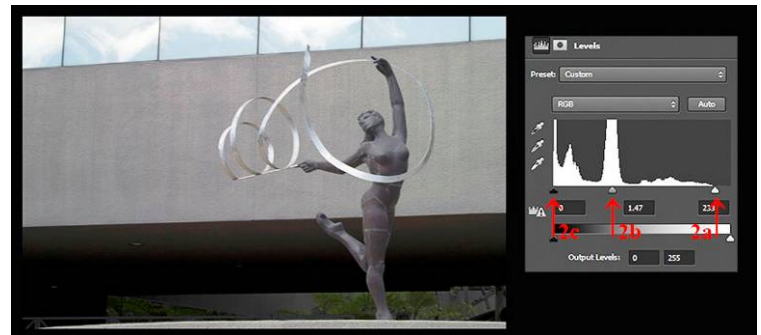

The second step is called equalization.

Equalization is usually performed with the "Levels tool". Note the histogram to the right of the cropped photo above. There is a blank gap in the highlight areas. Step 2a is to slide the small white marker until it just touches the histogram. Step 2b is to adjust the gray marker until the mid-tones have a more pleasing appearance. Step 2c was not done here because the dark areas of the histogram are already piled against the wall. If there had been a gap here, then before the gray marker was moved, the black marker would have been moved until it just touched the histogram.

The image now has a full tonal range but it could stand some improvement in the contrast. There are several ways to do this. The contrast adjustment is seldom the best.

We used the "Curves tool" instead. Note the curved diagonal line over the histogram. It was straight with a slope of 1. Note how the point 3a was pulled down slightly and the point 3b was pushed up slightly. This made the slope between those points steeper, which increases the contrast over the parts of the histogram that have the most important image content. At the same time, the slopes in the shadow area and the highlight area have been reduced. This lowers the contrast in the shadows & highlights slightly but it doesn't turn the shadows to black and blow out the highlights the way the contrast tool would.



We now have a nicely cropped photo with good tonal range and good contrast in the important areas without over darkening the shadows or blowing out the highlights.

Now for that cherry on top. For step 4, we will add some vignetting. During the renaissance master painters learned how to direct the viewer's eye to the important parts of the image by making them lighter relative to the rest of the image. If you have a program that can use layers with masks, the same curves tool we just used for contrast adjustment can create excellent vignetting.



In the image above, note the Layer mask (4b) in the lower right corner. This was created by selecting an elliptical area around the statue and then inverting the selection to select everything but the statue. This selection was then converted into a mask for a new curves layer. We want the vignetting to guide the eye to the statue without being conspicuous. So a Gaussian blur of several hundred pixels was applied to the mask. This will make our shading gradual and un-noticeable; but it will still be very effective. Finally, for step 4b we will use the curves tool to lower the gamma of the areas surrounding the statue. This is done by dragging a point directly in the center of the graph downwards to taste. The statue brighter by comparison to the surroundings and attracts the viewer's eye.

Many other techniques of photo editing and using layers were discussed during the two meetings.

#### At the October meeting

There are many styles of Panoramic Photographs and many methods for making them. We will examine the pros and cons of different methods and styles and some of the ordinary & special cameras that can be used.

One of the more recent techniques uses a cell cam that allows the photographer to spin around while the camera automatically creates the finished panorama. **If any of you have one of those cameras please bring it to the meeting.**

Another recent technique is similar to a fish eye photo; but it has single point perspective with straight horizontal & vertical lines. It is very adaptable in the effects it can create. Five years ago, I visited a submarine with an 11—16 mm zoom lens when the idea for this type of shot occurred to me. I have just acquired the necessary combination of Lens, Camera, Tripod and Software to take the test of concept photo shown below. I believe it is the very first of its kind. Its unusual form of distortion can be tamed or made even more extreme.



Come to the meeting and learn how it was made.

*This SIG meets in Science 131A at 10:30 a.m.*

---

## Linux Desktop & Administration

---

*By Tommy Crenshaw, Acting NOCCC SIG Leader; Bob Palmer, Contact Person*

Bob Palmer wasn't at the September meeting, so he had nothing to report.

*These SIGs meet in Science 131 at 9:00 and 10:30 am.*

---

## NOCCC Bylaws

The club's Bylaws are available at:  
[www.noccc.org/bylaws-as-amended-1-4-9.pdf](http://www.noccc.org/bylaws-as-amended-1-4-9.pdf)

## PC Q&A

By Jim Sanders, NOCCC SIG Leader

I was off enjoying a vacation on Kauai and didn't hold my SIG for the first time in a lot of years, so there is no meeting to report on. However, this article covers some keyboard shortcuts in WIN 7, a subject that is far too often forgot about. I say some keyboard shortcuts because there are way too many for a short article and I am only going to mention a



few of the ones that I think are most useful. MS says, "Keyboard shortcuts are combinations of two or more keys that, when pressed, can be used to perform a task that would typically require a mouse or other pointing device. Keyboard shortcuts can make it easier to interact with your computer, saving you time and effort as you work with Windows and other programs. Most programs also provide accelerator keys that can make it easier to work with menus and other commands. Check the menus of programs for accelerator keys. If a letter is underlined in a menu that usually means that pressing the Alt key in combination with the underlined key will have the same effect as clicking that menu item. Pressing the Alt key in some programs, such as Paint and WordPad, shows commands that are labeled with additional keys that you can press to use them."

Most of you should already know about the most commonly used keys, Ctrl+a, +c, +v, +x, +y, +z. But it has been rumored that more than half of you don't know that Ctrl+Z = Undo an action, and Ctrl+Y = Redo an action. How many times have you deleted some text or a sentence by mistake, took your right hand off the keyboard, grabbed the mouse, found the cursor, moved it to the Edit menu, left clicked to open the menu, moved the cursor to the Undo entry, and left clicked to Undo your mistake when you could have simply used Ctrl+Z. Now be honest! Which is more efficient? Which is easier? Which is worth training a few cells of the old gray matter to remember that.

With no apologies to anyone who happens to be a member of PETA, there are multiple ways to skin a cat, some messier than others. In a similar vein, there are often multiple ways to open a program in Windows. People can be a creature of habit. When they learn one way to do something, they will often stick with that procedure because they don't know that there is a better way. I watched one user who actually left clicked on the Start Logo, hovered over the "All Programs" line until the list appeared, moved the cursor to the down arrow at the bottom of the scroll bar, left clicked until the Accessories folder appeared, clicked on the Accessories logo to open those options, and then clicked on Windows Explorer to open the program.

I watched another who had been shown how useful the "Search Programs and Files" line can be. She left clicked on the Start Logo, typed in "windows," waited until Windows Explorer

appeared on the list and then clicked on it to open the program. I have watched a large number of people use the mouse to left click on the Start Logo to bring up that menu so they could left click on the "Computer" option to bring up Windows Explorer because that is the way they learned how. Then there are those who have learned that right clicking on the Start logo pops up a menu that allows them to left click on the Windows Explorer option.

Personally, I prefer to depress and hold the Windows Logo Key and then tap the "e" key to open Windows Explorer. Yes, clicking on the folder Icon on the taskbar is another easy way to open Windows Explorer, but the default for that action is to open Windows Explorer pointing to Libraries. I prefer to have Windows Explorer open pointing to "Computer." I also find that to depress and hold the Windows Logo Key and then tap the "e" key again, is the way I like to open a second Windows Explorer window. However, once you have the first Windows Explorer open, Ctrl+n will also open a new Explorer window.

I have been asked why you would want to have two Windows Explorer windows open at the same time. The answer is that it makes Moving, Copying and other file manipulations easier. That is particularly true when you can see both windows at the same time. Again, there are multiple ways that you can make that happen. Grabbing a side, top, bottom or corner with the mouse cursor, resizing the window and dragging them both around the desktop until they fit is one way.

Click and hold the top edge of the first window and quickly dragging it off the desktop to the left will result in that window taking up the left half of the desktop. Click and hold the top edge of the second window and quickly dragging it off the desktop to the right will result in that window taking up the right half of the desktop.

But to return to the keyboard short cuts, once you have two Windows Explorer windows open, the Windows logo key +L will cause the active window to take up the left half of the desktop. Clicking on the second Windows Explorer window to make it active and then using the Windows logo key + R will cause that window to take up the right half of the desktop.

So two lessons here. One, learning (and remembering) keyboard shortcuts can save you a lot of time and effort. Two, in Win 7 there are often multiple ways to achieve the same end result. See you next month.

*These SIGs meet in Irvine Hall at 10:30 a.m. and 12:30 p.m.*

---

## Microsoft Access

---

*By Bob Dickson, NOCCC SIG Leader*

The September session was a grand refresher time. Over a year ago or so, we (a club member and I) had built a couple of databases for her home projects. Time had passed and other activities had consumed most of her time. The database projects had grown 'misty' in her memory. So we used the session to reveal and revel in those projects, reactivating understanding of them and how they worked. Ahhh, yes, that's how that is performed. While not new, it was rewarding to go through those projects again and bring them up to renewed understanding. We talked of another project she might have. Projects do not have to be earth-shakers. They're for personal use and personal education. We decided, after some time in discussion, that a new project would be a database of names and addresses. Not a unique application but building a personal database is for fun and education. So during September, I'll work on some ideas about this project and in October we'll explore the parameters of it and set some goals. Then the fun will begin as we start from scratch and build a new database of names and addresses that will contain some unique and personal features that she'll desire to be included. It'll be educational and fun. That's what these SIG sessions are for. Do you have a unique and wonderful Access database you've built and are willing to share with other members? Have a desire to build a personal database? Come up to Sci 306 and let's have a grand time exploring the Access database.

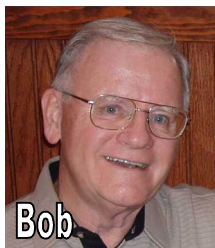

*This SIG meets in Science 306 at 10:30 a.m.*

---

## Visual Basic for Applications

(Access/Excel VBA)

*By Bob Dickson, NOCCC SIG Leader*

The September session was a rewarding experience: it provided the answer that had eluded efforts of a couple of persons over a great period of time. The problem was how to hide and unhide columns in a worksheet using program code. This can be done easily by the operator by highlighting the desired columns, right clicking them, and clicking on 'hide' or 'unhide'. The question was raised in the July session by a member who used Excel to manage his stock investments. He has several stocks in his worksheet, each of which uses a certain number of columns. In the rows in those columns, he enters various data on cost per share, change in cost, total value of the shares, and other desired data. When a stock is no longer of interest, he hides the columns, and later deletes the columns. How to do this by code rather than require the operator to manually perform the function. His request in the July session was for me to provide a solution if I could because he just could

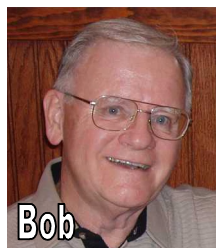

not find a method to perform this function. It turned out to be a time-consuming effort on my part, which, in the end, turned out to have a simple solution. There is code to perform this function – it's just not easy to find it. I could not find it in any of my tech texts, and I could not find a solution using the Excel Help function. But the solution was available all the time – in Google! Well, not Google as such but log on to Google and type in "Hide columns in Excel VBA" and up pops a whole string of sites with sample code to solve this problem. Give it a try. It seems there's a solution for every question out on the Internet. I hadn't used Google search before this. I'm a devotee now! The code is something like  
"Worksheets("Stocks").Columns("E:H").EntireColumn.Hidden = True" or ".....EntireColumn.Hidden = False".

BUT ... it turned out the solution was too limited! Yes, any column or number of columns could be hidden or unhidden provided you specified the names of the columns. Oops. Since columns were inserted and deleted over time, the named columns changed over time. To delete the columns for a stock, use code like

"Worksheets("Stocks").Range("E:H").EntireColumn.Delete xlShiftToLeft". This deletes columns E-F-G-H and shifts all the columns to the right of H to the left and renames the shifted columns using the names just deleted: E-F-G-H. Hardcoding column names just wouldn't work for this application since the names of the columns containing the stock of interest changed as stocks were entered and deleted over time. Much time was invested in trying to come up with a method that was not constrained by specific column names.

It was just due to trial and error and persistence that I found a method that got around having to use specific column names. My solution was to DIM a variable, say ax5 as a Variant. The program maintains a dynamic table of column names for each stock. As a stock is entered or deleted, the table is updated with the latest column names. When a stock is to be hidden (not deleted) or unhidden, the names of the first and last columns are retrieved from the table and placed in named variables, say ax1 for the leftmost column and ax2 for the rightmost column. Then the two names are put into the ax5 variant, conjoined with a colon (ax5 = ax1 & ":" & ax2). The code to hide/unhide the columns could then be entered as  
"Worksheets("Stocks").Columns(ax5).EntireColumn.Hidden = True or ..... Hidden = False". The program will now dynamically hide/unhide stocks, stocks can be entered or deleted and named columns do not have to be entered by the operator. (The column names are dynamically maintained in the table and are retrieved when needed.)

It was a lively and educational session. Very rewarding. If you have a question about VBA or have worked on a wonderful program and are willing to share your results, come up to Sci 306 and let's discuss it.

*This SIG meets in Science 306 at 12:00 noon.*

---

## Exploring New Technology

---

*By Ben Lochtenbergh, NOCCC SIG Leader*

What will the topic be this month? Perhaps reporting on my BYO PC project. I'm working on taking advantage of Microsoft before their TechNet rule changes go into effect. This has been discussed in earlier ENT SIG meetings. My problem is to find the time to do this. My desktop computer is a slow 3½ years old HP TV PC. Microsoft is ending their liberal policy of providing a wide array of software for a low subscription price to computer enthusiasts like me on September 30.

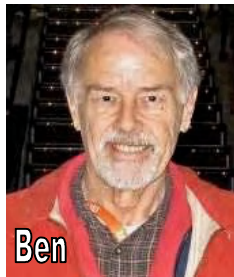

*This SIG meets in Science 109 at 9:00 am*

---

## Mobile Computing

---

*By Ben Lochtenbergh, NOCCC SIG Leader*

Preview of what going to be discussed during the October 6 meeting. Limited, yet perhaps too much detail, about the **successful SIM card strategy** that I planned for months for my foreign vacation now and in the future! Some hurdles had to be overcome and I'll include them too.

The plan was to buy a SIM card upon landing at the airport in Athens, Greece. I learned that SIM cards and prepaid telephone plans can be bought at post offices including the one at the airport. However, that post office couldn't help me because they don't carry the microSIM card required for my Samsung Galaxy S4 Google Play Edition phone. In the future they may, I assume. The lady at the post office knew immediately what the problem was. She said we only sell regular and miniSIM cards. A typical problem I'm too familiar with and one I often run into when using the latest technology. She referred me to a store called Grepmanoi, which supposedly does sell microSIM cards. **There actually was a branch of that company at the airport!** The problem was the store is in the departing passenger area and airport security would not allow me-in no uncertain terms-to go from Arrivals to Departures. My only option was to go to the Grepmanoi store in downtown Athens. Did you know that SIM cards originally were the size of a credit card?

After checking into the hotel my wife and I went to visit that store. I had to learn about taking the metro to Syntagma square (1.40 Euros per person), we had to walk about six blocks, I asked two people (a street vendor and a shopkeeper) for directions. **They both knew the store!** Having the store name written on a piece of paper was most helpful.

The Grepmanoi store was all about phones, yet it took them 20-30 minutes of work to get my new SIM card working in my phone. They taped my existing T-Mobile SIM card onto the plastic card they punched my new Cosmo SIM card out of. When I returned to California, all I had to do is put my card back into my S4 phone and T-Mobile worked immediately. I

**22** **NOCCC Orange Bytes** **October 2013**

paid 5.00 Euro (via a credit card for the SIM card) and bought 20.00 Euro (cash) for my prepaid plan. I should have bought a plan for 7.00 Euros or less because the promised refund (language problem?) was not to be gotten when I tried when departing Athens. This was the airport store that was previously inaccessible to me. The guy in the store said a refund is not possible, "just call someone in your country". I did call my sister in Holland (the sister that won a router in the August NOCCC raffle) from the Athens airport (she had just returned from her trip to America) thereafter I got busy with other vital things and dropped my interests in my foreign SIM card. On the Internet or supposedly at any post office I could have added more money to my prepaid telephone plus data account but that was not necessary because I had 17.00 Euros left at the end of my overseas stay.

While in Greece I was able, without any problem, to call individuals, hotels and taxis. I had a normal speed Internet access in the middle of the Aegean Sea while moving on a hydrofoil ferry. I could see 'the blue dot' move on the Google Maps app from island to island. I knew the name of each port-of-call before the public announcements in Greek and English. I wowed a few fellow passengers with my S4 phone!

**For 12.00 Euros (\$15) or less, you too** can get telephone service in another country like Greece **if you get** the kind of deal I have with T-Mobile.

I've already spoken and written about my deal with T-Mobile but here goes it again. I bought my phone (\$700) unlocked (without a telephone company contract). I played with the phone for two weeks going onto the Internet via Wi-Fi, taking photographs, etc. After two weeks I went to WalMart, bought a T-Mobile SIM card (about \$10 for the USA) and got myself a prepaid telephone contract for \$30 per month. I created an automatic refill account and added \$100. I won't have to do any work except monitor the accounts at my convenience. I can cancel or switch to AT&T any month, get their SIM card, and get a T-Mobile refund. Doing this I figure on paying half after 2 years of what I would have paid with a 2-year telephone company contract.

I don't like to advertise for any company but this deal is too good not to tell. What I'm hoping for is to find others with the same phone to do things with such as exchange ideas and learn things from.

I'll answer all questions at the MC SIG and show the box and papers all in Greek.

*This SIG meets in Science 109 at 10:30 am.*

## Club Business

### Proposed New STEM SIG

By Rudy Lauterbach, NOCCC Webmaster

Educators have been talking about emphasizing STEM (Science, Technology, Engineering and Math) in schools at all levels for the past few years. This would be to counteract the TAM attitudes (teenage adolescent moron fascination with social media/networking and game playing) so prevalent in today's youth.

For more information, see O.C.Register, Sunday, April 7, 2013, Commentary, page 4 and the October 2012 issue of "Communications of the ACM" (Association of Computing Machinery): "Computer Science and the Three R's -- A growing sense of crisis prevails as computer science searches for its place in the K-12 curriculum."

It might make sense for NOCCC to institute a STEM SIG where each of these four topics was addressed, round-robin style, each month. There could be four SIG Leaders, each knowledgeable in one of these areas, so each leader only had to be "ready" three times a year. I volunteer to do technology (Web authoring, Single Board Computers, etc). Are there any volunteers for science, engineering, and math? I know we have some math magicians out there.

If you are interested in participating as either a leader or just attending the SIG Meeting, let me know at [rblauter@cs.com](mailto:rblauter@cs.com) or put a comment on the Community Bulletin Board on the club website.

### Board Meeting Minutes September 9, 2013

#### September 9, 2013 Executive Board Meeting Report

Present: Don Armstrong, Steven Breitbart, Terry Dickson, Larry Klees, Rudy Lauterbach, Ben Lochtenbergh, Richard Miller and Gerry Resch.

Not Present: Tia Christian, Dallas Hazleton, John Heenan and Jim Sanders.

President Don Armstrong started the meeting at 7:37 p.m. at his house.

#### Club Issues by Don Armstrong

The first thing Don did was to congratulate Rudy for the presentation he made on September 1 about the NOCCC website. Don plans to meet with Dr. Fahy of Chapman University this week regarding selecting a student to get the NOCCC 2013 scholarship and having students give presentations at the NOCCC meetings.

Don confirmed that Larry will be speaking in October. His topic will be a continuation on how digital imaging is changing our

lives. Don said that we will try to have another 3D printer speak in November. He has found information about 3D printing from several sources. Richard mentioned that several companies in Orange County are making new products using 3D printing.

Don said he plans to give out NOCCC logo pens to executives at Chapman University, to October meeting attendees, to guest presenters and to each raffle. We will also give them to members for a \$5 donation and \$10 for non-members. The club bought 200 pens for \$500.

#### Treasurer's Report by John Heenan

No report was given at the meeting because John was not present. However, he sent a spreadsheet in an email noting the income and costs of the meeting. Money collected for coffee and donuts was \$23.00 but the cost was \$29.95 for a net loss of \$6.95. The raffle raised \$50.00. Net for the day was \$43.05.

Don reported that the club's liability insurance has been renewed and that we have one new member. Also that all of our accounts appear to be in order and the club is still viable.

#### September 1 NOCCC Meeting by Don Armstrong

Terry questioned the idea of having meetings on holiday weekends. Steven mentioned that the International Street Fair, which makes driving in the area more difficult, is held on Labor Day weekend. The start of the Chapman University semester also occurs in early September. Going forward, Don said we would try to get the second Sunday of the month in September. Steven recommended suspending the September meeting unless we can meet on the second Sunday.

#### SIG Attendance Report by Dallas Hazleton

Don asked if the SIGs were attended well. The SIG report was not presented at the meeting because Dallas wasn't there, but he sent the information in an email.

Linux for Desktop Users 5, Visual Programming 0, Exploring New Technology 3, Beginners Digital Photography 6, Microsoft Word, Etc. 1, Beginners PC Q & A 0, Linux Administration 4, Apple Products 12, Advanced Digital Photography 6, Understanding Operating Systems 0, Mobile Computing 0, Visual Basic For Applications 4, Microsoft Access 3, Advanced PC Q & A 0. Total SIG attendance was 44 people. Main Meeting 22.

An attendance sheet was circulated by Tia at the Main Meeting, which Don now has, but did not bring to the meeting. Attendance was taken at the digital photography SIG, but also was not brought to the meeting.

Larry said he was surprised by how many people came to the digital photography SIG even though it was a holiday weekend. It was supposed to be beginning and advanced meetings on GIMP. It actually became one long meeting, with more advanced topics near the end. Don asked Larry if there are topics for beginners and for advanced photographers. Larry said that Beginning and Advanced were just arbitrary labels in order to have two different SIGs because there is so much material to

cover and that there is a lot of overlap. Much discussion followed. Don said there were a good number of people in the Apple SIG. Terry said people came into the Linux SIG because several SIGs did not meet.

#### **Publications by Steven Breitbart**

Larry said that he deleted the photos of the Raffle winners in error but recovered a few. Steven said that he will use old photos of the winners when necessary.

John Heenan has been sending emails to Steven and Bob Weisensee, the printer, about two copies of the August 2013 Orange Bytes that were returned. The copies were returned due to excessive thickness. John took these two copies to the Post Office, explained the situation and the Postal employee weighed them and said they were too heavy. The Postal employee did not address the subject of thickness. Note that the Post Office took over a month to return the newsletters. John didn't state whose Orange Bytes were rejected or when or where they were rejected. The newsletters are sent out first class mail on *the same day* the printer gets the newsletter PDF and member list.

The conclusion was that we pay the additional postage per copy or Steven would try to lighten the newsletter by making the newsletter 24 pages long. Steven noted that it would be relatively easy to go to 24 pages this month because several SIG leaders were out and may not write SIG reports. John will be communicating with the printer about putting a fourth sticky tab on the copies; the potential cost is not yet known. Richard said the increase in postage would be 25¢ per copy.

Larry said we have always been close to the weight limit. Richard said the Post Office used to sample several copies at two different locations when we used bulk mail. Larry said if it is a thickness problem, it may be due to machinery. Don said that if only two were rejected, we shouldn't make changes just yet, Larry agreed. If it occurs again we should check out our options in mail classes and/or changing the size of the newsletter.

Rudy asked if any people volunteered to help with the Orange Bytes. Steven said that no one did. A few people did request Word and Excel tips in the menu and/or ribbon styles.

#### **Committee Reports – Programs Committee**

Steven asked if he should contact Factory eNova, a local computer controlled laser engraving business, to be a speaker. He described a bit of what they can do, somewhat simplified: First, you take a class in how to work with their equipment and software. Then, you join the business as you would a gym. Next, you bring them a digital drawing, preferably using Corel Draw. Their software converts the drawing into something the computer controlled laser engraver can use. They have three engravers and one 3D printer. They can do engraving on several materials and even on curved surfaces. Discussion followed, but the consensus was that Steven should see if they would do a presentation later in the year.

#### **Website by Rudy Lauterbach**

Rudy wants suggestions for what to include on the NOCCC website. He suggested a Google feature that would let people

find the latitude and longitude of their homes. Steven said that if you can get the information from Google, then we don't need it on the club website. Steven asked which browsers don't work with our website. Rudy said he's tried several popular browsers and they all work. Rudy suggested a lottery number picker. Some discussion followed on the legal issues regarding picking lottery numbers and rules for raffles for a non-profit organization.

#### **Raffle by Gerry Resch**

Don said the raffle went well. Gerry said that about the same amount of money was raised even though we had two-thirds of the typical attendance because the people who usually buy tickets were there.

#### **Public Relations Report by Tia Williams**

No report because Tia was not present.

#### **Old Business**

Don brought up having a display of old computers at Chapman University. Richard has already talked to a man in the Chapman library and it was suggested that we look for some other location on campus. Richard suggested that Jim would know what would be required for this type of display. Don asked if we know if club members have items that could be displayed. Terry asked if the display would become part of the campus property. Richard said no, it's a loan and Don said it would be similar to items loaned to a museum. Larry said that about 20 years ago, we had a portable computer museum that was kept by Tracy Lenocker, but he would be surprised if it still exists.

Gerry gave out old NOCCC literature to the Board Members. He estimated they were 15 years old. Some of the addresses and phone numbers are no longer valid.

Steven said that Jim said we need a 25-ft long VGA cord, an HDMI to VGA adapter and a mini-HDMI to VGA adapter. Larry said he lives close to Orvacs and will check again.

#### **New Business**

Steven said he got a call from a former member named Joe Sherry, who wants to drop off old software at the Consignment Table to give away. Steven said that you have to be a member to sell things, but is it OK for Joe to give things away? Everyone said yes. Richard said it is a donation to the club.

A motion was made by Steven to adjourn the meeting. It was seconded by Larry and passed unanimously. The meeting was adjourned at 8:53 p.m.

---

## **From the Desk of the Membership Chairman**

---

*By Ben Lochtenbergh, NOCCC, [bal@msn.com](mailto:bal@msn.com)*

No report was submitted.



## NOCCC Fee Schedule

The fee schedule has been set up to increase club membership, attract people with an interest in computing, and attract local computer-related businesses to place ads in the Orange Bytes with or without becoming NOCCC members. **We are also offering members the opportunity to help our club financially by making donations that should be income-tax deductible since we are chartered as a non-profit 501(c)(3) organization.** Donors will be acknowledged in the Orange Bytes and the Membership level will be shown on the Member's Badge. **Your regular dues are tax deductible!**

Membership Level (\$)	1 Year	3 Years
Individual Member .....	35	90
Each Additional Family Member .....	15	40
Full-Time* Enrolled College Student.....	20	
Enrolled High School Student .....	15	
*Minimum 12 Semester Hours		
Business Member + Ad (Business Card).....	180	
Business Member + Ad (¼ Page, ½ Page).....	465	800
Business Member + Ad (Full Page).....	1,475	
Membership Donations (\$)		
Contributing Member .....	75	
Supporting Member .....	100	
Advocate Member.....	250	
Patron Member .....	500	

## Thanks to Our Renewed Members for August 2013

- ❖ Charles A Moore
- ❖ Bill Van Horn

The following gems are from <http://unbelievable-facts.Tumblr.com> which references the source.

- A woman from Michigan named Barbara Soper gave birth on 10/10/10, 09/09/09 and 08/08/08 — The odds of this are 50 million to one.
- Both of Jack Black's parents were rocket scientists and his mother worked on the Hubble Telescope.
- Due to the high ratio of atmospheric density to surface gravity on Saturn's moon Titan, humans could fly by simply strapping on a pair of wings.
- Paypal-accidentally-credits-man-92-quadrillion.

## Location & Transportation Info.

### Meeting Information

The NOCCC meetings are held at Chapman University, in the Hashinger Science Center and Irvine Hall, near the northwest corner of Center Street and Palm Avenue.

### Parking Information

Most of this information is on the back cover. For more information, see

[www.chapman.edu/discover/\\_files/pdfs/Parking13-14.pdf](http://www.chapman.edu/discover/_files/pdfs/Parking13-14.pdf).

Several maps are available of the Chapman University campus and surrounding area at [www.chapman.edu/discover/maps-directions/index.aspx](http://www.chapman.edu/discover/maps-directions/index.aspx)

### Bus Service

Several Orange County Transportation Authority (OCTA) buses service Chapman University. Route 54 runs East and West on Chapman Ave. The 59 runs North and South on Glassell Avenue, but doesn't start early enough for the 9:00 a.m. SIGs. Get the most current information or use a trip planner at [www.octa.net](http://www.octa.net). OCTA also has a Consumer Relations office at (714) 636-7433 (RIDE).

### Railroad Service

Metrolink trains can get you to the NOCCC meeting from the Inland Empire. There are stops in the cities of Riverside, Corona, and Anaheim Hills. Parking your vehicle is free at the train station. (See **M** on map below.)

On Sundays, Inland Empire-Orange County Line train 859 leaves San Bernardino destined for Orange County at 8:55 am. For the return trip, train 858 leaves nearby Orange Metrolink at 3:55 pm and train 860 leaves at 5:35 pm. The Metrolink station is four-and-a-half blocks from Chapman University. For specifics regarding your trip, check the web site: <http://www.metrolinktrains.com> or call 1-800-371-5465.



## FREE AD SPACE

If you are a NOCCC member, and have a computer-related, non-commercial or "Talent Available" ad that you would like to have placed in this newsletter or on the NOCCC web site, send an e-mail with a copy of your business card or ad to the NOCCC Editor at [editor@noccc.org](mailto:editor@noccc.org)

**Classified ads by NOCCC members:**  
**\$5 for 1 to 25 words**  
**\$10 for 26 to 50 words**

*Commercial display advertisements  
are welcome, contact  
[editor@noccc.org](mailto:editor@noccc.org).*

### RATES

One Page Vertical	.....7.0" x 9.5"	..... \$150
Half-page Horizontal	.....7.0" x 5.0"	..... \$80
Half-page Vertical	.....3.5" x 9.5"	..... \$80
Quarter-page	.....3.5" x 5.0"	..... \$45
Business Card	.....3.5" x 2.0"	..... \$ 15
Center Spread	..... 14.0" x 9.5"	..... \$300

### Deadline: Tenth of the month

Discounts: 3months=10%, 6=15%, 12=20%

If you are interested in advertising in the publications of multiple User Groups throughout the region or nationally, you can learn more by contacting <http://www.apcug.org>

Readers, please tell our advertisers that you saw their ad in the  
*Orange Bytes*

## LIGAS

Microsystems

Custom systems built, Repair, Sales, Training

714-544-3589

[jsanders@ligasmicro.com](mailto:jsanders@ligasmicro.com)



**Your Business Card  
would look good here!!**

*For information about  
advertising in the Bytes, contact:*

*[editor@noccc.org](mailto:editor@noccc.org)*

## Publication Information

Orange Bytes is published monthly by:  
North Orange County Computer Club  
P.O. Box 3616, Orange, CA 92857

All opinions expressed herein are those of the individual authors only and do not necessarily represent the opinions of the NOCCC, its officers, Board of Directors, the *Orange Bytes* newsletter staff or its editors. The NOCCC does not guarantee the accuracy or the correctness of advertising or articles in the *Orange Bytes*, nor does the NOCCC intend to endorse, rate, or otherwise officially comment on products available. Therefore, readers are cautioned to rely on opinions presented exclusively at their own risk.

**Trademarks/Copyrights** — The mention of names of products in this publication without trademark or copyright symbols does not imply that they are not so protected by law. All trademarks are the property of their respective owners.

**Production** — *Orange Bytes* was produced with Microsoft Word<sup>®</sup> using the True Type fonts Arial, Benguiat Bk BT, and Times New Roman.

**Printed by: Creative Technology**

5959 Palmer Blvd.

Sarasota, FL 34232—28

800-533-1031



## Membership Renewal

When you turn in your renewal with this form & cash or check, include your membership number & name, and only demographics that changed since the last renewal.

Memberships also may be renewed by credit card at:

<https://ipn.intuit.com/pay/NorthOccc>

To stay up-to-date with Club news & have full access to the NOCCC web site, send e-mail address changes to [membership@noccc.org](mailto:membership@noccc.org)

### QUICK MEMBERSHIP APPLICATION/RENEWAL

Date: \_\_\_\_\_ I am a new member   
This is a renewal; my membership number is \_\_\_\_\_

**PLEASE PRINT!**

Name \_\_\_\_\_

Address \_\_\_\_\_

City \_\_\_\_\_

State \_\_\_\_\_ Zip \_\_\_\_\_ Phone (\_\_\_\_\_) \_\_\_\_\_ - \_\_\_\_\_

email \_\_\_\_\_

**Fees: See page 25 for fee schedule; \$35 for single membership.**

Since the North Orange County Computer Club is incorporated as a 501 (c) (3) organization, checks are 100% tax deductible when made payable to North Orange County Computer Club.

Amount enclosed \$ \_\_\_\_\_

MC / Visa No. \_\_\_\_\_ Expires \_\_\_\_\_

Please make your check payable to North Orange County Computer Club and mail with your application to:

**North Orange County Computer Club**

**PO Box 3616**

**Orange, CA 92857**

North Orange County Computer Club  
PO Box 3616  
Orange, CA 92857

Members: Your expiration month  
and year appear above your address.  
Please renew promptly using the  
application inside.

## Dated Material - Please deliver by October 2, 2013

### Are You a NOCCC Member?

#### Consider all that you get with membership and Join Now!

- **Meetings.** Keep up with what's going on in the computer world. Hear outstanding industry representatives make presentations of the latest and greatest in computer products.
- **Special Interest Groups.** Our SIGs cover a broad spectrum of computer issues. Whether you are a beginner or a power user, attend the lectures and demonstrations, and share your knowledge about computers.
- **Raffle Drawings.** We have distributed thousands of dollars worth of hardware, software, and books as prizes at our Main Meeting.
- **Consignment Table.** We have a consignment table during even-month meetings, in which members can sell or buy all kinds of computer & software items.
- **Get help with your current computer problems.** In the Random Access portion of the Main Meeting, you may ask your question of the entire assemblage. More than likely, someone will have the answer.
- **NOCCC Help Line.** NOCCC volunteers, experts in their fields, are ready to assist you with your computer problems. They can be contacted by email or by telephone.
- **The Orange Bytes Newsletter.** Our award-winning newsletter reports on club activities and provides articles about current computer issues and reviews of software and books.
- **Product Reviews.** Write a review for the *Orange Bytes* and keep the software, hardware, book, or CD!
  - **Volunteer Work.** We have numerous interesting assignments available. As an all-volunteer organization, you can join with other members in a variety of activities: solicit newsletter ads, write newsletter articles, run a SIG, give a Main Meeting presentation, show new members around, join the board, assist in setting up the meeting or participate in computer-related community volunteer work.
  - Become a NOCCC member by signing up at the Reviews/Membership Desk during a general meeting, usually the first Sunday of the month.

Or simply fill out the form on the reverse side of this page and send it in.

**Meeting Information** — The NOCCC meeting is held at Chapman University, in the Hashinger Science Center and Irvine Hall, near the northwest corner of N. Center St. and E. Palm Ave.

**Parking Information** - Chapman University's main parking lot is the underground Lastinger Parking Structure under Wilson field on the north side of the campus. Enter from Walnut Avenue, just east of Glassell Street. Parking is not free on Sunday, even if the gate is up. **However, the permit vending machine is about 100 feet south of the entry area. There are other machines elsewhere in the lot.** Find one, buy a permit, and put it on your dashboard. Do not park in any other lot, in a reserved space, or back into a space.

Free street parking also is available on the campus-side of the streets only. Parking in front of any residential housing will result in an expensive parking ticket. A City of Orange public parking lot, located on the southwest corner of E. Maple and N. Orange, is also free and only 2 blocks from the meeting. For more information, see the Transportation Information section.

